

L76&L76-L

Hardware Design

GNSS Module Series

Version: 3.3

Date: 2023-07-04

Status: Released



At Quectel, our aim is to provide timely and comprehensive services to our customers. If you require any assistance, please contact our headquarters:

Quectel Wireless Solutions Co., Ltd.

Building 5, Shanghai Business Park Phase III (Area B), No.1016 Tianlin Road, Minhang District, Shanghai 200233, China

Tel: +86 21 5108 6236

Email: info@quectel.com

Or our local offices. For more information, please visit:

<http://www.quectel.com/support/sales.htm>.

For technical support, or to report documentation errors, please visit:

<http://www.quectel.com/support/technical.htm>.

Or email us at: support@quectel.com.

Legal Notices

We offer information as a service to you. The provided information is based on your requirements and we make every effort to ensure its quality. You agree that you are responsible for using independent analysis and evaluation in designing intended products, and we provide reference designs for illustrative purposes only. Before using any hardware, software or service guided by this document, please read this notice carefully. Even though we employ commercially reasonable efforts to provide the best possible experience, you hereby acknowledge and agree that this document and related services hereunder are provided to you on an “as available” basis. We may revise or restate this document from time to time at our sole discretion without any prior notice to you.

Use and Disclosure Restrictions

License Agreements

Documents and information provided by us shall be kept confidential, unless specific permission is granted. They shall not be accessed or used for any purpose except as expressly provided herein.

Copyright

Our and third-party products hereunder may contain copyrighted material. Such copyrighted material shall not be copied, reproduced, distributed, merged, published, translated, or modified without prior written consent. We and the third party have exclusive rights over copyrighted material. No license shall be granted or conveyed under any patents, copyrights, trademarks, or service mark rights. To avoid ambiguities, purchasing in any form cannot be deemed as granting a license other than the normal non-exclusive, royalty-free license to use the material. We reserve the right to take legal action for noncompliance with abovementioned requirements, unauthorized use, or other illegal or malicious use of the material.

Trademarks

Except as otherwise set forth herein, nothing in this document shall be construed as conferring any rights to use any trademark, trade name or name, abbreviation, or counterfeit product thereof owned by Quectel or any third party in advertising, publicity, or other aspects.

Third-Party Rights

This document may refer to hardware, software and/or documentation owned by one or more third parties (“third-party materials”). Use of such third-party materials shall be governed by all restrictions and obligations applicable thereto.

We make no warranty or representation, either express or implied, regarding the third-party materials, including but not limited to any implied or statutory, warranties of merchantability or fitness for a particular purpose, quiet enjoyment, system integration, information accuracy, and non-infringement of any third-party intellectual property rights with regard to the licensed technology or use thereof. Nothing herein constitutes a representation or warranty by us to either develop, enhance, modify, distribute, market, sell, offer for sale, or otherwise maintain production of any our products or any other hardware, software, device, tool, information, or product. We moreover disclaim any and all warranties arising from the course of dealing or usage of trade.

Privacy Policy

To implement module functionality, certain device data are uploaded to Quectel’s or third-party’s servers, including carriers, chipset suppliers or customer-designated servers. Quectel, strictly abiding by the relevant laws and regulations, shall retain, use, disclose or otherwise process relevant data for the purpose of performing the service only or as permitted by applicable laws. Before data interaction with third parties, please be informed of their privacy and data security policy.

Disclaimer

- a) We acknowledge no liability for any injury or damage arising from the reliance upon the information.
- b) We shall bear no liability resulting from any inaccuracies or omissions, or from the use of the information contained herein.
- c) While we have made every effort to ensure that the functions and features under development are free from errors, it is possible that they could contain errors, inaccuracies, and omissions. Unless otherwise provided by valid agreement, we make no warranties of any kind, either implied or express, and exclude all liability for any loss or damage suffered in connection with the use of features and functions under development, to the maximum extent permitted by law, regardless of whether such loss or damage may have been foreseeable.
- d) We are not responsible for the accessibility, safety, accuracy, availability, legality, or completeness of information, advertising, commercial offers, products, services, and materials on third-party websites and third-party resources.

Copyright © Quectel Wireless Solutions Co., Ltd. 2023. All rights reserved.

Safety Information

The following safety precautions must be observed during all phases of operation, such as usage, service, or repair of any terminal or mobile incorporating the module. Manufacturers of the terminal should notify users and operating personnel of the following safety information by incorporating these guidelines into all product manuals. Otherwise, Quectel assumes no liability for customers' failure to comply with these precautions.



Ensure that the product may be used in the country and the required environment, as well as that it conforms to the local safety and environmental regulations.



Keep away from explosive and flammable materials. The use of electronic products in extreme power supply conditions and locations with potentially explosive atmospheres may cause fire and explosion accidents.



The product must be powered by a stable voltage source, and the wiring shall conform to security precautions and fire prevention regulations.



Proper ESD handling procedures must be followed throughout the mounting, handling and operation of any devices and equipment that incorporate the module to avoid ESD damages.

About the Document

Document Information

Title	L76&L76-L Hardware Design
Subtitle	GNSS Module Series
Document Type	Hardware Design
Document Status	Released

Revision History

Version	Date	Description
-	2013-02-08	Creation of the document
1.0	2013-02-08	First official release
1.1	2013-03-21	<ol style="list-style-type: none"> Deleted PMTK 291 command. Changed R3 to 100R in figure 17. Updated chapter 2.4. Changed typical voltage of V_BCKP to 3.3 V.
1.2	2014-05-10	<ol style="list-style-type: none"> Modified the input power at RF_IN. Changed the tracking sensitivity to -165 dBm.
1.3	2014-06-11	<ol style="list-style-type: none"> Updated packaging information.
2.0	2014-08-28	<ol style="list-style-type: none"> Added related information of L76B module. Added the description of power supply requirement.
2.1	2015-11-11	<ol style="list-style-type: none"> Added the description of 1PPS VS NMEA. Added the information about L76G module.
3.0	2016-04-26	<ol style="list-style-type: none"> Deleted the information about L76G module. Added the information about L76-L module. Added chapter 3.9: EPO Data Service
3.1	2016-05-18	Added the description of I2C about L76-L module.

Version	Date	Description
3.2	2021-08-16	<ol style="list-style-type: none"> Deleted the information about L76B; Added the information about the L76-L(L) module; Updated the name of PIN2 from TXD1 to TXD; Updated the name of PIN3 from RXD1 to RXD; Updated the name of PIN9 from RESET to RESET_N; Updated the name of PIN14 from VCC_RF to VDD_RF; Updated the name of PIN18 from WAKE_UP to WAKEUP; Added chapters 1.5, 1.6, 3.1, 3.4, 3.5, 5.2.2, 5.3, 8.2, and 9; Updated the maximum altitude and accuracy of 1 PPS signal value (Table 2); Added the GLP mode (Chapter 3.3.5); Updated the reference design for I2C interface (Figure 12); Updated the recommended reflow soldering thermal profile (Chapter 8.3).
3.3	2023-07-04	<ol style="list-style-type: none"> Updated the module height size (Chapter 1.1, Table 1 and Figure 26). Updated the weight and added the number of concurrent GNSS (Table 1). Added the power data for power consumption (Table 2). Updated the manufacturing and soldering (Chapter 8.3).

Contents

Safety Information.....3

About the Document.....4

Contents.....6

Table Index.....8

Figure Index.....9

1 Product Description..... 10

 1.1. Overview..... 10

 1.2. Features 11

 1.3. Performance..... 13

 1.4. Block Diagram 14

 1.5. GNSS Constellations 14

 1.6. Augmentation System 15

 1.6.1. SBAS..... 15

 1.7. AGNSS..... 15

 1.7.1. EASY..... 15

 1.7.2. EPO..... 16

 1.8. LOCUS 16

 1.9. Multi-tone AIC..... 16

2 Pin Assignment..... 18

3 Power Management 21

 3.1. Power Unit..... 21

 3.2. Power Supply 22

 3.2.1. VCC..... 22

 3.2.2. V_BCKP 23

 3.3. Power Mode 24

 3.3.1. Continuous Mode 24

 3.3.2. Standby Mode 24

 3.3.3. Backup Mode 25

 3.3.4. Periodic Mode 26

 3.3.5. GLP Mode 27

 3.3.6. AlwaysLocate™ Mode 28

 3.4. Power-up Sequence..... 29

 3.5. Power-down Sequence 30

4 Application Interfaces 31

 4.1. I/O Pins..... 31

 4.1.1. Communication Interfaces 31

 4.1.1.1. UART Interface..... 31

 4.1.1.2. I2C Interface 32

 4.1.2. ANTON..... 33

4.1.3.	1PPS	33
4.1.4.	System Pin	34
4.1.4.1.	RESET_N	34
5	Design	36
5.1.	Antenna Design.....	36
5.1.1.	Antenna Specification	36
5.1.2.	Antenna Selection Guide	36
5.1.3.	Active Antenna Reference Design.....	37
5.1.3.1.	Active Antenna Reference Design without ANTON	37
5.1.3.2.	Active Antenna Reference Design with ANTON	38
5.1.4.	Passive Antenna Reference Design	39
5.1.4.1.	Passive Antenna Reference Design without Additional LNA	39
5.1.4.2.	Passive Antenna Reference Design with Additional LNA	39
5.2.	Coexistence with Cellular Systems.....	40
5.2.1.	In-band Interference.....	41
5.2.2.	Out-of-band Interference.....	42
5.2.3.	Ensuring Interference Immunity	42
5.3.	Recommended Footprint.....	44
6	Electrical Specification.....	45
6.1.	Absolute Maximum Ratings	45
6.2.	Recommended Operating Conditions.....	46
6.3.	ESD Protection.....	47
7	Mechanical Dimensions	48
7.1.	Top, Side and Bottom View Dimensions	48
7.2.	Top and Bottom Views	49
8	Product Handling	50
8.1.	Packaging.....	50
8.1.1.	Tapes	50
8.1.2.	Reels	51
8.2.	Storage	51
8.3.	Manufacturing and Soldering	52
9	Labelling Information	54
10	Appendix References	55

Table Index

Table 1: Product Features.....	11
Table 2: Product Performance	13
Table 3: GNSS Constellations and Frequency Bands.....	15
Table 4: I/O Parameter Definition	18
Table 5: Pinout	19
Table 6: Recommended Antenna Specifications.....	36
Table 7: Intermodulation Distortion (IMD) Products.....	42
Table 8: Absolute Maximum Ratings	45
Table 9: Recommended Operating Conditions.....	46
Table 10: Reel Packaging	51
Table 11: Recommended Thermal Profile Parameters	53
Table 12: Related Documents.....	55
Table 13: Terms and Abbreviations	55

Figure Index

Figure 1: Block Diagram.....	14
Figure 2: Pin Assignment.....	18
Figure 3: Internal Power Supply.....	22
Figure 4: VCC Input Reference Circuit.....	23
Figure 5: RTC Powered by Non-rechargeable Battery.....	23
Figure 6: Reference Charging Circuit for a Rechargeable Battery.....	24
Figure 7: Enter/Exit from Backup Mode Sequence.....	26
Figure 8: Periodic Mode.....	27
Figure 9: AlwaysLocate™ Mode.....	28
Figure 10: Power-up Sequence.....	29
Figure 11: Power-down Sequence.....	30
Figure 12: UART Interface Reference Design.....	31
Figure 13: RS-232 Level Shift Circuit.....	32
Figure 14: I2C Interface Reference Design for L76-L Module.....	33
Figure 15: 1PPS & NMEA Timing.....	34
Figure 16: Reference OC Circuit for Module Reset.....	34
Figure 17: Reset Sequence.....	35
Figure 18: Active Antenna Reference Design without ANTON.....	37
Figure 19: Reference Design for Active Antenna with ANTON.....	38
Figure 20: Passive Antenna Reference Design without Additional LNA.....	39
Figure 21: Reference Design for Passive Antenna with Additional LNA.....	40
Figure 22: In-band Interference on GPS L1.....	41
Figure 23: Out-of-band Interference on GPS L1.....	42
Figure 24: Interference Source and Its Path.....	43
Figure 25: Recommended Footprint.....	44
Figure 26: Top, Side and Bottom View Dimensions.....	48
Figure 27: Top and Bottom Views.....	49
Figure 28: Tape and Reel Specifications.....	50
Figure 29: Recommended Reflow Soldering Thermal Profile.....	52
Figure 30: Labelling Information.....	54

1 Product Description

1.1. Overview

The document contains L76, L76-L, L76-L(L) modules. You can choose the dedicated module based on your requirement.

The modules support multiple global positioning and navigation systems: GPS, GLONASS, Galileo, BDS and QZSS. These modules also support SBAS (including WAAS, EGNOS, MSAS and GAGAN) and AGNSS functions. The default constellation configuration is GPS + GLONASS.

Key features:

- All the modules are single-band, multi-constellation GNSS devices and feature high-performance and high reliability positioning engines. The modules facilitate a fast and precise GNSS positioning capability.
- All the modules support serial UART communication interfaces. I2C is only supported by L76-L module.
- Embedded with many advanced power saving modes including GLP, AlwaysLocate™, Standby and Backup, the modules feature low-power consumption in different scenes.
- All the modules are featured with EASY™ technology, one kind of AGNSS. Capable of collecting and processing all internal aiding information like GPS time, ephemeris, last position, etc., the modules deliver a very short Time to First Fix (TTFF) in either hot or warm start.
- The embedded flash memory provides the capacity for storing user-specific configurations and future firmware updates.
- L76 and L76-L, the standard I/O voltage variants, have **2.7–2.9 V** I/O voltage; L76-L(L), the low I/O voltage variant has a **1.7–1.9 V** I/O voltage.
- The three module variants are of a SMD form factor measuring 10.1 mm x 9.7 mm x 2.3 mm and can be embedded in your application using the 18 LCC pins.
- The three modules are EU ROHS Directive compliant.

1.2. Features

Table 1: Product Features

Features		L76	L76-L	L76-L(L)
Grade	Industrial	●	●	●
	Automotive	-	-	-
Category	Standard Precision GNSS	●	●	●
	High Precision GNSS	-	-	-
	DR	-	-	-
	RTK	-	-	-
	Timing	-	-	-
VCC Supply	2.8–4.3 V, Typical: 3.3 V	●	●	●
V_BCKP Supply	1.5–4.5 V, Typical: 3.3 V	●	●	●
I/O	Typical: 2.8 V	●	●	-
	Typical: 1.8 V	-	-	●
Communication Interfaces	UART	●	●	●
	SPI	-	-	-
	I2C ¹	-	●	-
Features	Additional LNA	-	●	●
	Additional Filter	●	●	●
	RTC crystal	●	●	●
	TCXO oscillator	●	●	●
	6-axis IMU	-	-	-
Constellations	Number of Concurrent	3 + QZSS	3 + QZSS	3 + QZSS

¹ The I2C interface is supported only on certain firmware versions.

Features		L76	L76-L	L76-L(L)	
and Frequency Bands	GNSS				
	GPS	L1 C/A	●	●	●
		L5	-	-	-
	GLONASS	L1	●	●	●
		E1	●	●	●
	Galileo	E5a	-	-	-
		B1I	●	●	●
	BDS	B2a	-	-	-
		QZSS	L1 C/A	●	●
	L5		-	-	-
	NavIC	L5	-	-	-
	SBAS	L1	●	●	●
	Temperature Range	Operating temperature range: -40 °C to +85 °C Storage temperature range: -40 °C to +90 °C			
	Physical Characteristics	Size: (10.1 ±0.15) mm × (9.7 ±0.15) mm × (2.3 ±0.20) mm Weight: Approx. 0.5 g			

NOTE

For more information about GNSS constellation configuration, see [document \[1\] protocol specification](#).

1.3. Performance

Table 2: Product Performance

Parameter	Specification	L76	L76-L	L76-L(L)
Power Consumption ²	Acquisition	25 mA (82.5 mW)	31 mA (102.3 mW)	31 mA (102.3 mW)
	Tracking	18 mA (59.4 mW)	31 mA (102.3 mW)	31 mA (102.3 mW)
	Standby mode	0.5 mA (1.65 mW)	0.5 mA (1.65 mW)	0.5 mA (1.65 mW)
	Backup mode	7 μ A (23.1 μ W)	8 μ A (26.4 μ W)	8 μ A (26.4 μ W)
Sensitivity	Acquisition	-148 dBm	-149 dBm	-149 dBm
	Reacquisition	-160 dBm	-161 dBm	-161 dBm
	Tracking	-165 dBm	-167 dBm	-167 dBm
TTFF ² (with AGNSS)	Cold Start	15 s	15 s	15 s
	Warm Start	5 s	5 s	5 s
	Hot Start	1 s	2 s	2 s
TTFF ³ (without AGNSS)	Cold Start	35 s	32 s	32 s
	Warm Start	30 s	30 s	30 s
	Hot Start	1 s	2 s	2 s
Horizontal Position Accuracy ⁴		2.5 m		
Update Rate		1 Hz (Max. 10 Hz)		
Accuracy of 1PPS Signal		Typical accuracy: 100 ns		
Velocity Accuracy ²		Without aid: 0.1 m/s		
Acceleration Accuracy ²		Without aid: 0.1 m/s ²		

² Room temperature, all satellites at -130 dBm.

³ Open-sky, active high precision GNSS antenna, less than 1 km baseline length.

⁴ CEP, 50 %, 24 hours static, -130 dBm, more than 6 SVs.

Parameter	Specification	L76	L76-L	L76-L(L)
Dynamic Performance ²		Maximum Altitude: 10000 m Maximum Velocity: 515 m/s Acceleration: 4g		

1.4. Block Diagram

The following figure shows a block diagram of the modules. The modules include a GNSS IC, an additional LNA (only supported by L76-L and L76-L(L)), an additional SAW filter, a TCXO and a XTAL. The LNA is less susceptible to in-band interference in challenged environment (i.e. with a cellular module transmitting B13 at the same time). This ensures enhanced performance in an environment where jamming may be encountered.

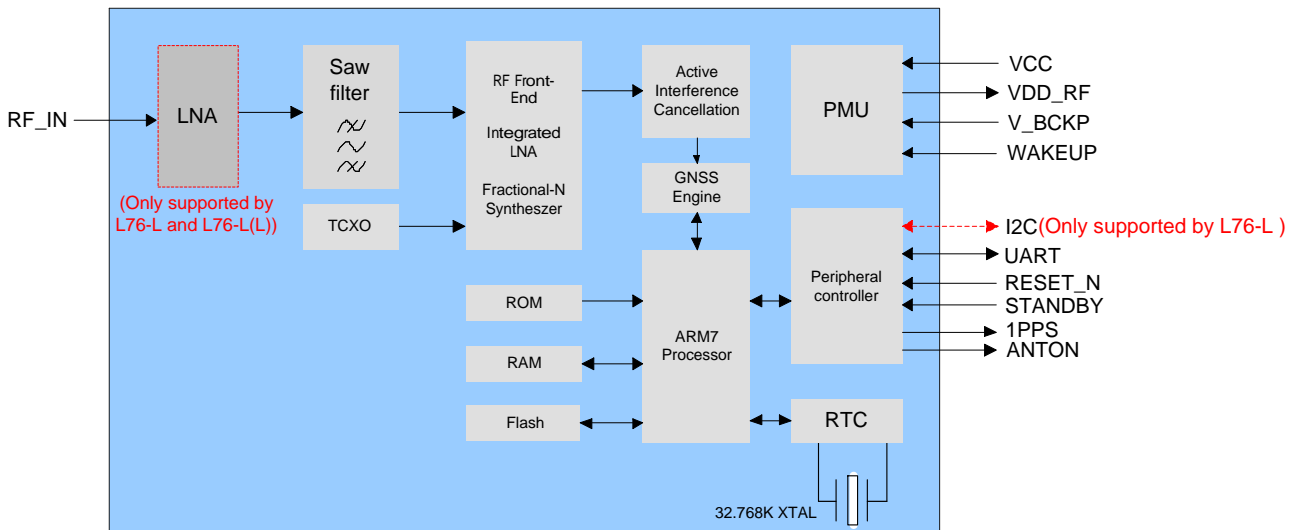

Figure 1: Block Diagram

1.5. GNSS Constellations

The module is a single-band concurrent GNSS receiver that can receive and track multiple GNSS signals. Owing to its RF front-end architecture, it can track the following GNSS constellations: GPS, GLONASS, Galileo, BDS, and QZSS, plus SBAS satellites. If low power consumption is a key factor, the module can be configured to track only a subset of GNSS constellations.

QZSS is a regional navigation satellite system that transmits signals compatible with the GPS L1 C/A, L1C, L2C and L5 signals for the Pacific region covering Japan and Australia. The module can detect and

track QZSS L1 C/A signal concurrently with GPS signals, leading to better availability especially under challenging conditions, e.g., in urban canyons.

Table 3: GNSS Constellations and Frequency Bands

System	Signal
GPS	L1 C/A: 1575.42 MHz
GLONASS	L1: 1602 MHz + K × 562.5 kHz, K= (-7 to +6, integer)
Galileo	E1: 1575.42 MHz
BDS	B1I: 1561.098 MHz
QZSS	L1 C/A: 1575.42 MHz

1.6. Augmentation System

1.6.1. SBAS

The modules all support SBAS (Satellite-Based Augmentation System) broadcast signal reception, and GPS data are complemented by additional regional or wide area GPS enhancement data. The system enhances the data through satellite broadcasting, and the data can be used in GNSS receivers to improve the accuracy of the results. SBAS satellites can also be used as additional signals for range or distance measurement, further improving availability. Supported SBAS systems include WAAS, EGNOS, MSAS and GAGAN.

1.7. AGNSS

The module supports AGNSS feature that significantly reduces the module’s TTFF, especially under lower signal conditions. To implement the AGNSS feature, the module should get the assistance data including the current time and rough position. For more information, see [document \[2\] AGNSS application note](#).

1.7.1. EASY

The modules support the EASY feature to improve TTFF and improve the acquisition sensitivity. To achieve that goal, the EASY feature provides assistant information, such as the ephemeris, almanac, last rough position, time, and a satellite status.

EASY feature works as embedded software which can accelerate TTFF by predicting satellite navigation messages from received ephemeris. The GNSS engine automatically calculates and predicts orbit information for up to 3 days after first receiving the broadcast ephemeris, and saves the predicted information into the internal memory. The GNSS engine will use the information for positioning if there is not enough information from satellites. As a result, the function is helpful for positioning and TTFF improvement.

The EASY function can reduce TTFF to 5 s in warm start. In this case, RTC domain should be valid. In order to gain enough broadcast ephemeris information from GNSS satellites, the GNSS module should keep tracking the information for at least 5 minutes in good signal conditions after it fixes the position.

EASY function is enabled by default. For more information about the corresponding command to disable EASY function, see [document \[1\] protocol specification](#).

1.7.2. EPO

The modules all feature a function called EPO (Extended Prediction Orbit) which is a world leading technology that supports 14-day orbit predictions to customers. Occasional download from the EPO server is needed. For more information, see [document \[2\] AGNSS application note](#).

1.8. LOCUS

These modules support the embedded logger function called LOCUS. This function can automatically log position information to internal flash memory when enabled by dedicated LOCUS commands. With this function, the host can save power consumption and does not need to track the NMEA information all the time. LOCUS provides typically more log capacity without any added costs.

Software commands can be used to query the current state of LOCUS. For more information about these commands, see [document \[1\] protocol specification](#).

The raw data which MCU gets must be parsed via LOCUS parser code provided by Quectel. For more details, please contact Quectel technical support.

1.9. Multi-tone AIC

The modules all support a function called Active Interference Cancellation (multi-tone AIC) to decrease harmonic distortion of GNSS signal induced by RF signal from Wi-Fi, Bluetooth, and the 2G and 3G networks.

Up to 12 multi-tone AIC embedded in each module can provide effective narrow-band interference and jamming elimination. The GNSS signal could be demodulated from the jammed signal, which can ensure better navigation quality. AIC function is enabled by default. For more information about the commands that can be used to set AIC function, see [document \[1\] protocol specification](#).

2 Pin Assignment

The modules are equipped with 18 LCC pins by which they can be mounted on the PCB.

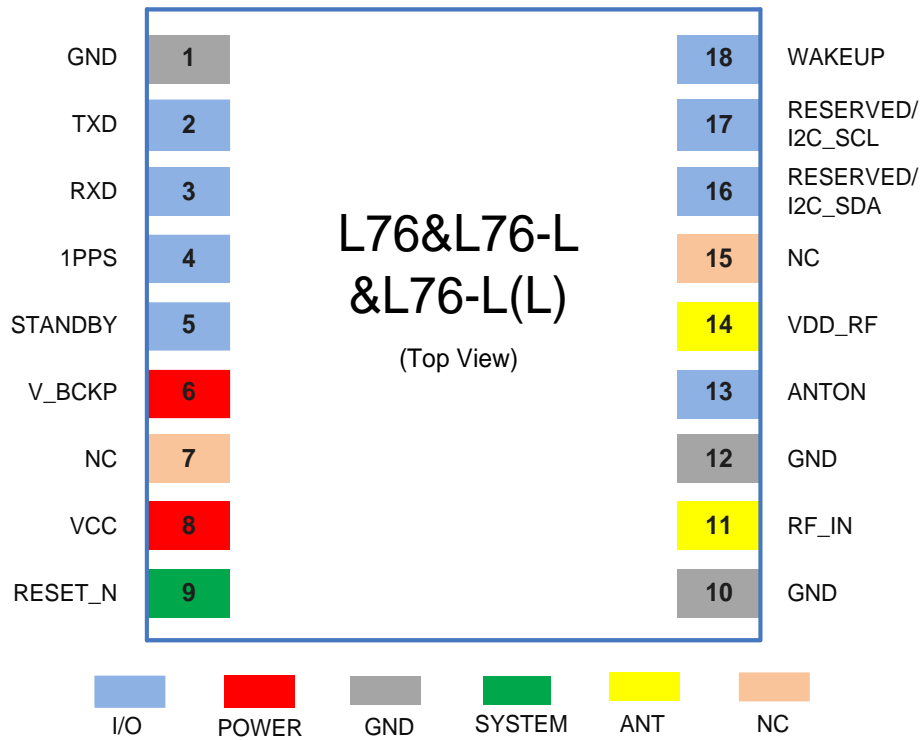

Figure 2: Pin Assignment

Table 4: I/O Parameter Definition

Type	Description
AI	Analog Input
DI	Digital Input
DO	Digital Output
DIO	Digital Input/Output

Type	Description
PI	Power Input
PO	Power Output

Table 5: Pinout

Function	Name	No.	I/O	Description	Remarks
Power	VCC	8	PI	Main power supply	Requires clean and steady voltage. Assure load current not less than 150 mA.
	V_BCKP	6	PI	Backup power supply for RTC domain	Supplies power to the RTC domain when VCC power supply is disconnected.
I/O	TXD	2	DO	Transmits data	UART port is used for NMEA output, PMTK/PQ commands input and firmware upgrade.
	RXD	3	DI	Receives data	
	RESERVED/ I2C_SDA	16	DIO	For L76/L76-L(L) modules, keep it open. For L76-L module, this pin is I2C_SDA.	For L76-L module, I2C Interface outputs NMEA data by default when reading; it can also receive PMTK/PQ commands through I2C bus.
	RESERVED/ I2C_SCL	17	DIO	For L76/L76-L(L) modules, keep it open. For L76-L module, this pin is I2C_SCL.	
	ANTON	13	DO	Control the ENABLE pin of additional LNA and the power supply of active antenna.	If unused, leave the pin N/C (not connected).
	STANDBY	5	DI	Enter or exit from Standby mode	The pin is pulled up internally. It is edge-triggered. If unused, leave the pin N/C (not connected).
	WAKEUP	18	DI	Wake up the modules from Backup mode	Keep this pin open or pulled low before entering Backup mode. It belongs to RTC domain. If unused, leave the pin N/C (not connected).
1PPS	4	DO	One pulse per second	Synchronized on rising edge, and the pulse width is 100 ms.	

Function	Name	No.	I/O	Description	Remarks
					If unused, leave the pin N/C (not connected).
Antenna	VDD_RF	14	PO	Power supply for external RF components	VDD_RF = VCC, the output current capacity depends on VCC. Typically used to supply power for an external active antenna or LNA. If unused, leave the pin N/C (not connected).
	RF_IN	11	AI	GNSS antenna interface	50 Ω characteristic impedance.
System	RESET_N	9	DI	Resets the modules	Active low.
GND	GND	1, 10, 12	-	Ground	Ensures good GND connections to all GND pins of the modules, with a large ground plane preferred.
NC	NC	7, 15	-	Not connected	If unused, leave the pin N/C (not connected).

NOTE

Leave RESERVED and unused pins N/C (not connected).

3 Power Management

These modules provide a power optimized architecture with built-in autonomous energy saving capabilities to minimize power consumption at any given time. The receiver can be used in six operating modes: Periodic mode, AlwaysLocate™ mode, GLP mode, Standby mode, and Backup mode for best power consumption and Continuous mode used for best performance.

3.1. Power Unit

VCC is the supply voltage pin of the modules. It supplies power for the PMU which in turn supplies the entire system and RTC domains. The load current of the VCC pin varies according to VCC voltage level, processor load, and satellite acquisition. It is important to supply sufficient current and make sure the power supply is clean and stable.

The V_BCKP pin supplies power for the RTC domain. If the VCC voltage drops under the acceptable level, the V_BCKP pin keeps the RTC domain powered. To achieve quick startup and improve TTFF, the RTC domain power supply should be valid during the interval when the VCC pin does not have a valid level. SRAM memory also belongs to the RTC domain. If the VCC is not valid, the V_BCKP pin supplies power for SRAM memory that contains all the necessary GNSS data and some of the user configuration variables.

VDD_RF is an output pin, equal in voltage to the VCC input. In Continuous mode, VDD_RF pin supplies power for the external active antenna or the LNA. In Standby mode, VDD_RF pin is turned off.

The two diodes in the following figure construct an OR gate to supply power for RTC domain. WAKEUP pin belongs to RTC domain. The signal shown as red line in Figure 3 can open and close the switch. The following steps will close or open the switch:

Step 1: The switch will be closed by default when VCC pin is supplying power (VCC off → on).

Step 2: Keeping WAKEUP open or low and sending PMTK command can open the switch (Continuous → Backup).

Step 3: Keeping WAKEUP logic high can close the switch (Backup → Continuous).

The modules' internal power supply is shown below:

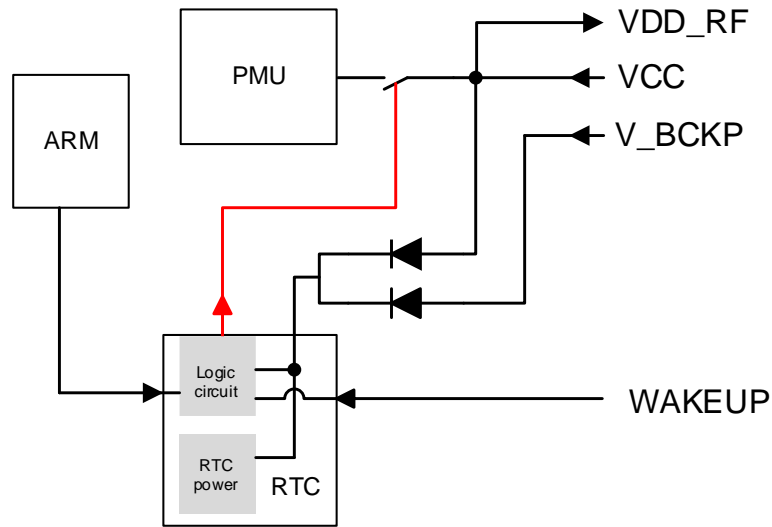

Figure 3: Internal Power Supply

3.2. Power Supply

3.2.1. VCC

The VCC pin supplies power for BB, RF, and RTC domain. VCC pin load current varies according to VCC voltage level, processor load and satellite acquisition state.

Module power consumption may vary in several orders of magnitude, especially when low power mode is enabled. Therefore, it is important that the power supply can sustain peak power for a short time, ensuring that the load current does not exceed the rated value. When the modules switch from Backup mode to normal operation or startup, it must charge the internal capacitors in the core domain. In some cases, this can lead to a significant current drain.

For low-power applications using power saving and backup modes, it is important that the LDO at the power supply or module input can provide the current/drain. An LDO with a high PSRR should be chosen for good performance. In addition, a TVS diode, and a combination of a 10 μ F, 100 nF and a 33 pF decoupling capacitor network should be added near the VCC pin. The lowest value capacitor should be the closest to module pins.

It is not recommended to use a switching DC-DC power supply.

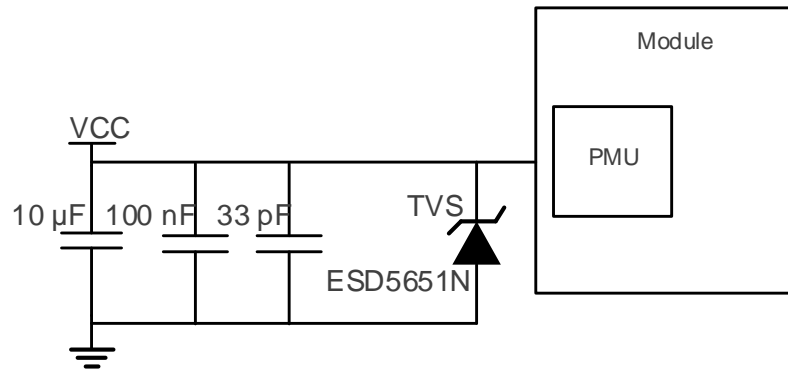

Figure 4: VCC Input Reference Circuit

3.2.2. V_BCKP

The V_BCKP pin supplies power for the RTC domain. If the module power supply fails, the V_BCKP pin supplies power for the real-time clock (RTC) and RAM. Use of valid time and GNSS orbit data at startup, allows GNSS hot (warm) start. If no backup power is connected, the modules perform a cold start at power up.

If there is a constant power supply in your system, it can be used to provide a suitable voltage to power V_BCKP.

V_BCKP can be directly powered by an external battery (rechargeable or non-rechargeable). It is recommended to place a battery with the combination of a 4.7 µF, a 100 nF and a 33 pF capacitor near the V_BCKP pin. The figure below illustrates the reference design for supplying power for the RTC domain with a non-rechargeable battery.

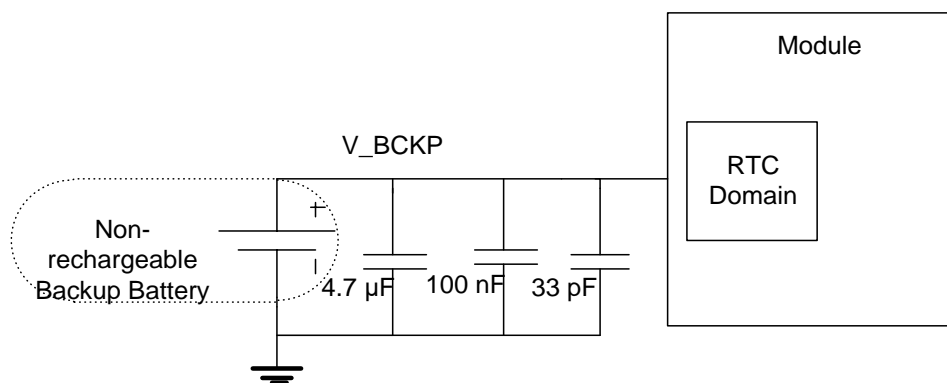

Figure 5: RTC Powered by Non-rechargeable Battery

If V_BCKP is powered by a rechargeable battery, it is necessary to implement an external charging circuit for the battery. A reference charging circuit is illustrated below.

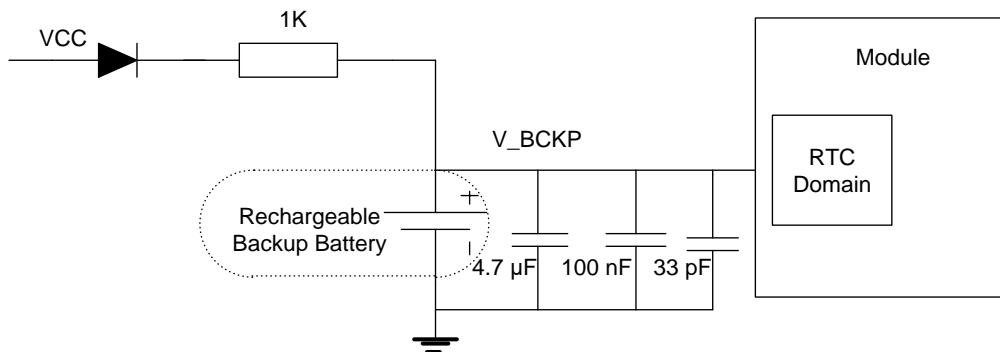

Figure 6: Reference Charging Circuit for a Rechargeable Battery

3.3. Power Mode

3.3.1. Continuous Mode

If VCC is powered on, the modules automatically enter Continuous mode. Continuous mode comprises acquisition mode and tracking mode. In acquisition mode, the modules start to search satellites, and to determine visible satellites, coarse frequency, as well as the code phase of satellite signals. When the acquisition is completed, the modules automatically switch to tracking mode. In tracking mode, the modules track satellites and demodulate the navigation data from specific satellites.

3.3.2. Standby Mode

Standby mode is a low-power consumption mode. In Standby mode, the internal core and I/O power domain are still active, but RF and TCXO are powered off, and the modules stop satellites search and navigation. The UART interface still receives commands or any other data in Standby mode, but NMEA messages can't be output via the interface.

The following describes how to enter or exit from Standby mode:

- Pulling STANDBY pin low will make the GNSS module enter Standby mode and releasing STANDBY pin which has been pulled high internally will make the modules back to Continuous mode. Note that pulling down STANDBY pin to ground will cause the extra current consumption which makes the typical Standby current reach to about 600 µA @ VCC=3.3 V.

- Sending corresponding command will make the modules enter Standby mode. Sending any data via UART will make the modules exit standby mode as UART is still accessible in Standby mode.

When the modules exit from Standby mode, it will use all internal aiding information like GPS time, ephemeris, last position, etc., resulting in the fastest possible TTFF in either hot or warm start. For more information about these commands to enter or exit from Standby mode, see [document \[1\] protocol specification](#).

NOTE

The STANDBY pin is edge-triggered, so the modules may unexpectedly enter Standby mode when it starts. To avoid this, it is recommended to set your GPIO which controls STANDBY pin as input before the modules start. After that, you can reset the GPIO as output to control the STANDBY pin. If it is unused, keep it open.

3.3.3. Backup Mode

For power-sensitive applications, the module receiver provides a Backup mode to reduce power consumption.

Backup mode requires lower power consumption than Standby mode. In this mode, the modules stop acquiring and tracking satellites. The UART is not accessible. But the backed-up memory in RTC domain which contains all the necessary GPS information for quick start-up and a small amount of user configuration variables is maintained. Due to the backed-up memory, EASY™ technology is available.

If the power supply to VCC pin is cut off and V_BCKP pin is powering the RTC domain, the modules switch from Continuous mode to Backup mode. Only RTC domain is active in Backup mode and it keeps tracking time. As soon as the VCC pin is powered, the modules immediately switch to Continuous mode.

The following describes how to switch between Backup mode and Continuous mode.

- Keep the WAKEUP pin open or low (the signal shown as red line in [Figure 3: Internal Power Supply](#)) and send software command to enter Backup mode. The only way to wake up the modules is by pulling the WAKEUP pin high (signal shown as a red line in [Figure 3: Internal Power Supply](#)). For more information about the command, see [document \[1\] protocol specification](#).
- Cutting off the power supply to VCC pin and keeping V_BCKP pin powered will make the modules exit from Continuous mode and enter Backup mode.

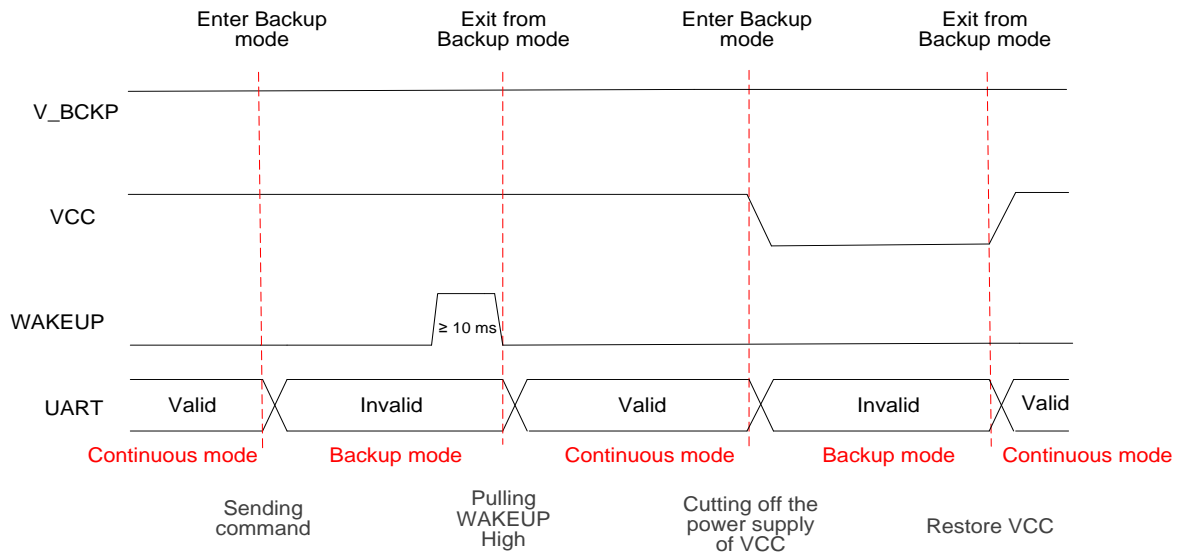

Figure 7: Enter/Exit from Backup Mode Sequence

NOTE

Keep WAKEUP pin open or low before entering Backup mode. Or else, the Backup mode will be unavailable.

3.3.4. Periodic Mode

Periodic mode is a mode that can control the Continuous mode and Standby/Backup mode periodically to reduce power consumption. It contains Periodic standby mode and Periodic backup mode.

The modules enter or exit from the Periodic mode through software commands. For more information about these commands, see [document \[1\] protocol specification](#).

The following figure has shown the operation of Periodic mode. When you send corresponding command, the modules will be into the Continuous mode. After several minutes, the modules enter the Periodic mode and follows the parameters. When the modules fail to fix the position in **Run time**, the modules will switch to **Second run time** and **Second sleep time** automatically. As long as the modules fix the position again, the modules will return to **Run time** and **Sleep time**.

The average current value can be calculated by the following formula:

$$I_{\text{periodic}} = (I_{\text{tracking}} \times T1 + I_{\text{standby/backup}} \times T2) / (T1 + T2)$$

T1: Run time, T2: Sleep time

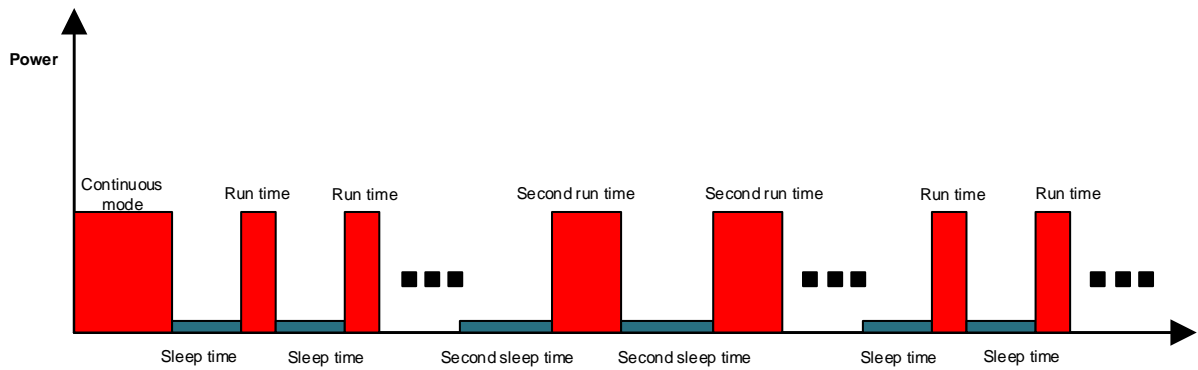

Figure 8: Periodic Mode

NOTE

1. The STANDBY pin is edge-triggered, so the modules may unexpectedly enter Periodic standby mode when it starts. To avoid this, it is recommended to set your GPIO which controls STANDBY pin as input before the modules start. After that, you can reset the GPIO as output to control the STANDBY pin. If it is unused, keep it open.
2. Keep WAKEUP pin open or low before entering Periodic backup mode. Or else, the Periodic backup mode will be unavailable.
3. Before entering Periodic mode, assure the modules are in the tracking mode; otherwise, the modules will have a risk of failure to track the satellite. If GNSS module is located under weak signal environment, it is better to set a longer Second run time to ensure the success of reacquisition.

3.3.5. GLP Mode

The GLP (GNSS Low Power) mode is an optimized solution for wearable fitness and tracking devices. It reduces power consumption by disabling high accuracy positioning.

In GLP mode, the modules provide relatively good positioning performance walking or running in dynamic scenarios. The modules automatically switch to Continuous mode under challenged environment to keep better accuracy. As a result, the modules can still achieve maximum performance with the lowest power consumption.

Software commands can make the modules enter or exit from GLP mode. For more information about these commands, see [document \[1\] protocol specification](#).

NOTE

1. When the modules enter GLP mode, the 1PPS and the SBAS functions are disabled.
2. In highly dynamic scenarios, the positioning accuracy of the modules in GLP mode is slightly reduced.

3.3.6. AlwaysLocate™ Mode

AlwaysLocate™ is an intelligent power saving mode. It contains AlwaysLocate™ backup mode and AlwaysLocate™ standby mode.

AlwaysLocate™ standby mode allows the modules to switch automatically between Continuous mode and Standby mode. According to the environmental and motion conditions, the modules can adaptively adjust the Continuous time and Standby time to achieve the balance between positioning accuracy and power consumption. Sending software command and the modules returning a corresponding command means the modules access AlwaysLocate™ standby mode successfully. It will benefit power saving in this mode. Sending software command in any time will make the modules back to Continuous mode.

AlwaysLocate™ backup mode is like AlwaysLocate™ standby mode. The difference is that AlwaysLocate™ backup mode switches automatically between Continuous mode and Backup mode. Sending software command makes the modules enter AlwaysLocate™ backup mode. Pulling WAKEUP high and immediately sending software command will make the modules enter Continuous mode.

For more information about these commands, see [document \[1\] protocol specification](#).

The position accuracy in AlwaysLocate™ mode will be degraded, especially in highly dynamic scenarios. The following figure shows the rough consumption in different scenes.

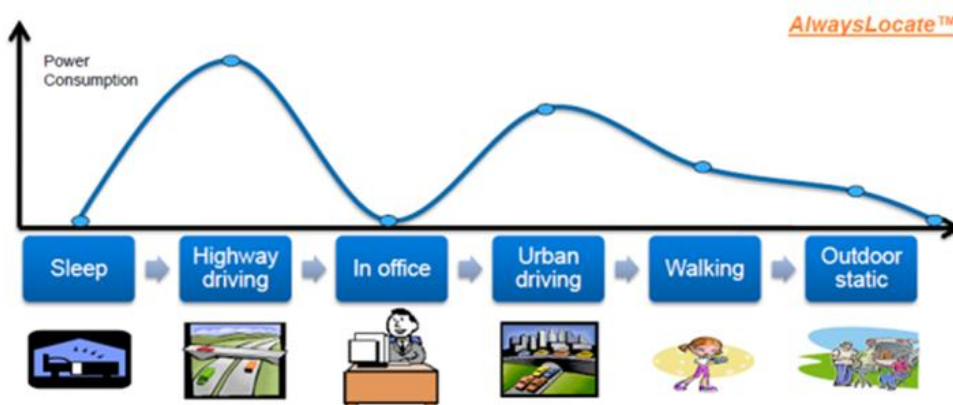

Figure 9: AlwaysLocate™ Mode

Example

The average consumption of the modules which are located outdoors in a static position and equipped with an active antenna after tracking satellites is about 2.7 mA in AlwaysLocate™ standby mode based on GPS + GLONASS.

The average consumption of the modules which are located in outdoors in static and equipped active antenna after tracking satellites is about 2.6 mA in AlwaysLocate™ backup mode based on GPS + GLONASS.

NOTE

1. The STANDBY pin is edge-triggered, so the modules may unexpectedly enter AlwaysLocate™ standby mode when they start. To avoid this, it is recommended to set your GPIO which controls STANDBY pin as input before the modules start. After that, you can reset the GPIO as output to control the STANDBY pin. If it is unused, keep it open.
2. Keep WAKEUP pin open or low before entering AlwaysLocate™ backup mode. Or else, the AlwaysLocate™ backup mode will be unavailable.

3.4. Power-up Sequence

When VCC is powered up, the modules start up automatically.

To ensure correct power-up sequence, the RTC logic should start up before the PMU. So, the V_BCKP must be supplied with power at the same time or before the VCC.

Ensure that the VCC has no rush or drop during rising time, and then keep the voltage stable. The recommended ripple is < 100 mV.

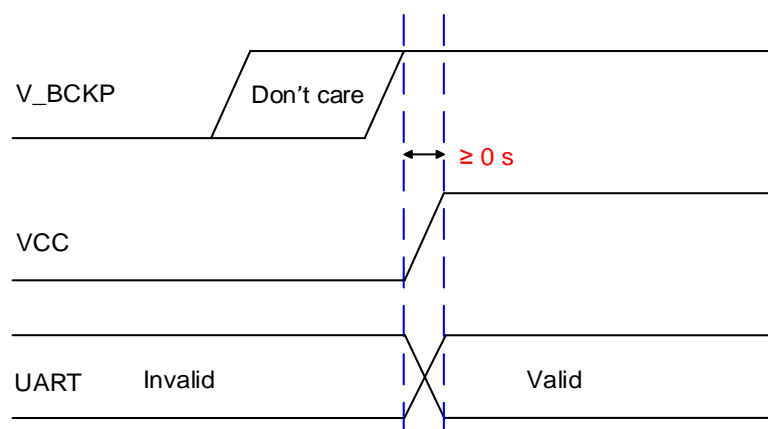

Figure 10: Power-up Sequence

3.5. Power-down Sequence

When the VCC is shut down, voltage should drop quickly with a drop time of less than 50 ms. It is recommended to use a voltage regulator that supports fast discharge.

To avoid abnormal voltage condition, if VCC falls below specified minimum value, the system must initiate a power-on reset by lowering VCC to less than 100 mV for at least 100 ms.

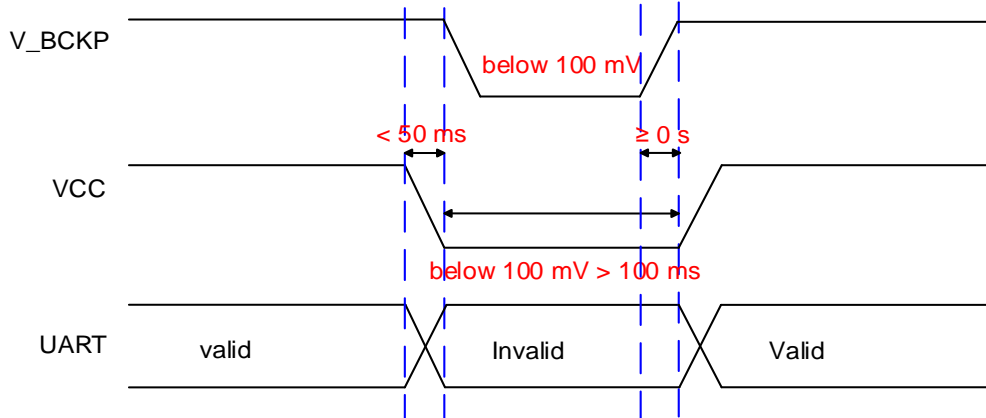

Figure 11: Power-down Sequence

4 Application Interfaces

4.1. I/O Pins

4.1.1. Communication Interfaces

The following interfaces can be used for data reception and transmission.

4.1.1.1. UART Interface

The three modules all provide one UART interface. The UART port has the following features:

- Support for firmware upgrade, NMEA output and PMTK/PQ proprietary messages input.
- Supported baud rates: 4800, 9600, 14400, 19200, 38400, 57600, 115200, 230400, 460800, and 921600 bps.
- Default settings: 9600 bps, 8 bits, no parity bit, 1 stop bit.
- Hardware flow control and synchronous operation are not supported.

A reference design is shown in the figure below.

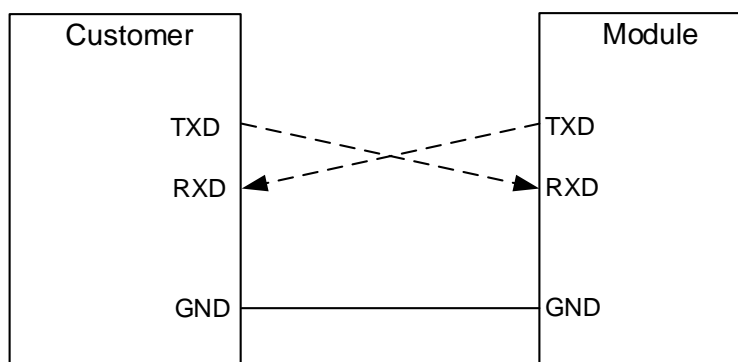

Figure 12: UART Interface Reference Design

NOTE

If the I/O voltage of MCU is not matched with that of the modules, a level shifter must be selected.

The UART port does not support the RS-232 level shifter but only CMOS level shifter. If the module's UART port is connected to the UART port of a computer, it is necessary to add a level shift circuit between the module and the computer. Please refer to the following figure.

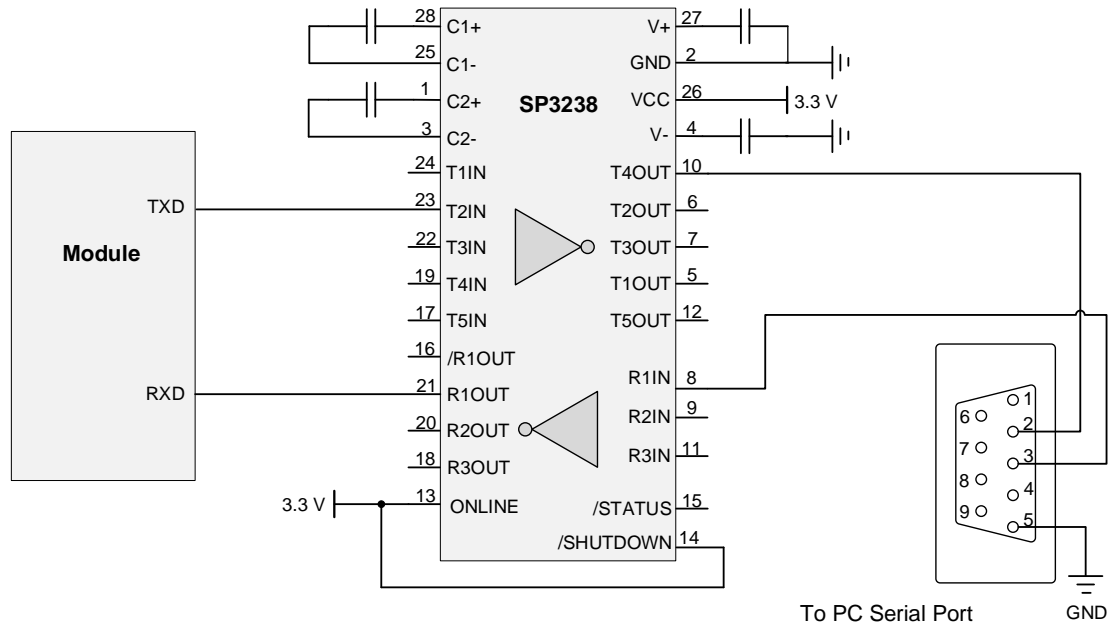

Figure 13: RS-232 Level Shift Circuit

NOTE

As the GNSS module outputs more data than a single GPS system, the default output NMEA messages running at 4800 bps baud rate and at a 1 Hz update rate may result in data loss. The solution to avoid losing data is to decrease the output NMEA types and increase the baud rate to 9600 bps.

4.1.1.2. I2C Interface

The L76-L module provides one I2C interface which is supported only on certain firmware versions. The I2C features are listed below:

- Supports NMEA data output and receive PMTK/PQ commands via I2C bus.
- Supports fast mode, with bit rate up to 400 kbps.
- Supports 7-bit address.
- Works in slave mode.
- Default I2C address values are: Write: 0x20; Read: 0x21.

For more information, see [document \[3\] reference design](#).

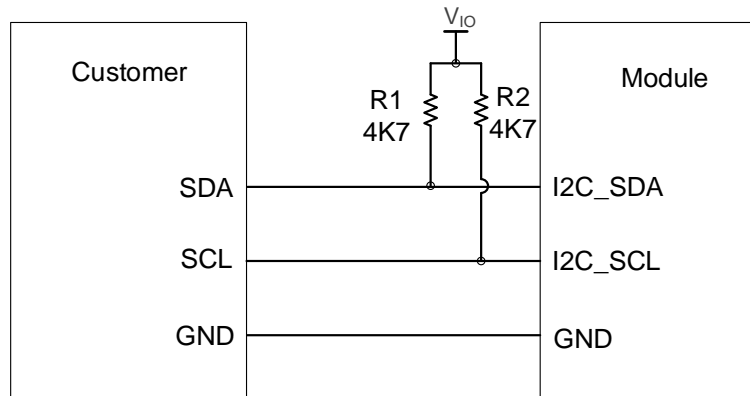

Figure 14: I2C Interface Reference Design for L76-L Module

NOTE

1. I2C_SDA/I2C_SCL should be externally pulled up to $V_{IO} = 2.8$ V.
2. The I2C voltage threshold of L76-L module is 2.8 V. If the system voltage of MCU is not consistent with it, a level shifter circuit must be used.

4.1.2. ANTON

The modules provide a pin called ANTON which is related to module state. Its voltage level will change in different module states. When the modules work in Continuous mode, this pin is in high level. While the modules work in Standby mode, GLP mode, Backup mode, AlwaysLocate™ mode, and during sleep time in periodic mode, this pin is in low level. Based on this characteristic, the ANTON pin can be used to control the power supply of active antenna or the ENABLE pin of the additional LNA to reduce power consumption.

4.1.3. 1PPS

The 1PPS output generates one pulse per second trains synchronized with a GPS or UTC time grid with intervals configurable over a wide range of frequencies. The accuracy is < 100 ns. Thus, it may be used as a low frequency time synchronization pulse or as a high frequency reference signal.

The latency range is 465-485 ms between the beginning of UART TXD and the rising edge of PPS.

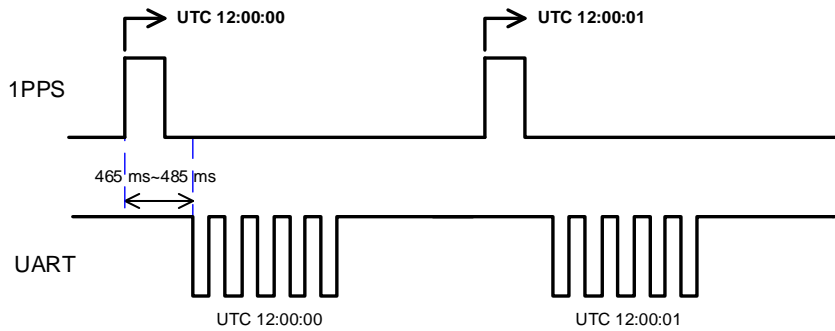

Figure 15: 1PPS & NMEA Timing

The feature only supports 1 Hz NMEA output at baud rate 19200-115200 bps. Because at lower baud rates, the time needed for transmission may exceed 1 second if there are many NMEA sentences. For more information about the commands to enable/disable this function, see [document \[1\] protocol specification](#).

4.1.4. System Pin

4.1.4.1. RESET_N

RESET_N is an input pin. The modules can be reset by driving RESET_N low for at least 100 ms and then releasing it.

The pin is pulled up internally by default. As the power domain of RESET_N is 2.8 V/1.8 V and the pin has been pulled up inside the modules, no external pull-up circuit is allowed for this pin.

An OC driver circuit as shown below is recommended to control the RESET_N pin.

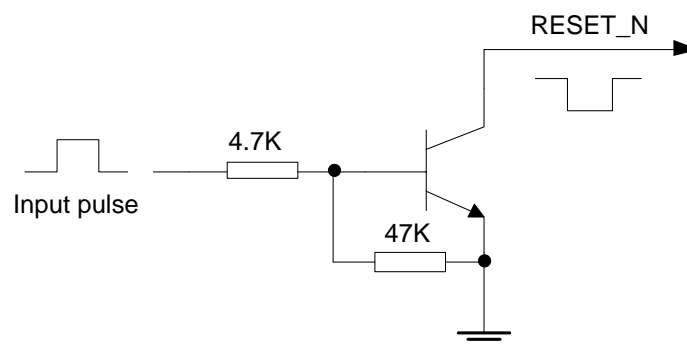

Figure 16: Reference OC Circuit for Module Reset

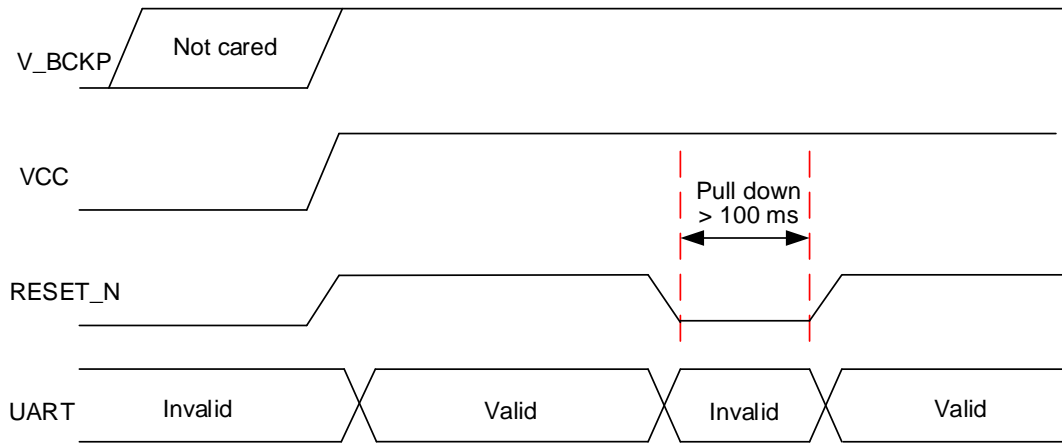

Figure 17: Reset Sequence

NOTE

1. Ensure RESET_N is connected so that it can be used to reset the modules if the modules enter an abnormal state.
2. The power domain of RESET_N is 2.8 V for L76/L76-L modules, 1.8 V for L76-L(L) module.

5 Design

5.1. Antenna Design

5.1.1. Antenna Specification

The module can be connected to a dedicated passive or an active single-band GNSS antenna in order to track the GNSS satellite signals. The recommended antenna specifications are given in the table below.

Table 6: Recommended Antenna Specifications

Antenna Type	Specifications
Passive Antenna	Frequency Range: 1559–1609 MHz Polarization: RHCP VSWR: < 2 (Typ.) Passive Antenna Gain: > 0 dBi
Active Antenna	Frequency Range: 1559–1609 MHz Polarization: RHCP VSWR: < 2 (Typ.) Passive Antenna Gain: > 0 dBi Active Antenna Noise Figure: < 1.5 dB Active Antenna Total Gain: < 18 dB

NOTE

1. For recommended antenna and design, see [document \[4\] GNSS antenna selection&application guide](#) or contact Quectel Technical Support (support@quectel.com).
2. The total antenna gain equals the internal LNA gain minus total insertion loss of cables and components inside the antenna.

5.1.2. Antenna Selection Guide

Both active and passive GNSS antennas can be used for the three modules. A passive antenna is recommended if the antenna can be placed close to the modules, for instance, when the distance between the modules and the antenna is less than 1 m. Otherwise, use an active antenna, since the

insertion loss of RF cable can decrease the CNR of GNSS signal.

CNR is an important factor for GNSS receivers, and it is defined as the ratio of the received modulated carrier signal power to the received noise power in one Hz bandwidth. CNR formula is as below:

$$\text{CNR} = \text{Power of GNSS signal} - \text{Thermal Noise} - \text{System NF(dB-Hz)}$$

The “Power of GNSS signal” is GNSS signal level. In practical environment, the signal level at the earth surface is about -130 dBm. “Thermal Noise” is -174 dBm/Hz at 290 K. To improve CNR of GNSS signal, a LNA could be added to reduce “System NF”.

“System NF”, formula:

$$\text{NF} = 10 \log F \text{ (dB)}$$

“F” is the noise factor of receiver system:

$$F = F1 + (F2 - 1)/G1 + (F3 - 1)/(G1 \cdot G2) + \dots$$

“F1” is the first stage noise factor, “G1” is the first stage gain, etc. This formula indicates that LNA with enough gain can compensate for the noise factor behind the LNA. In this case, “System NF” depends mainly on the noise figure of components and traces before first stage LNA plus noise figure of LNA itself. This explains the need for using an active antenna, if the antenna connection cable is too long.

5.1.3. Active Antenna Reference Design

5.1.3.1. Active Antenna Reference Design without ANTON

The following figure is a typical reference design of an active antenna without ANTON. In this case, the antenna is powered by the VDD_RF. When selecting the active antenna, it is necessary to pay attention to operating voltage range.

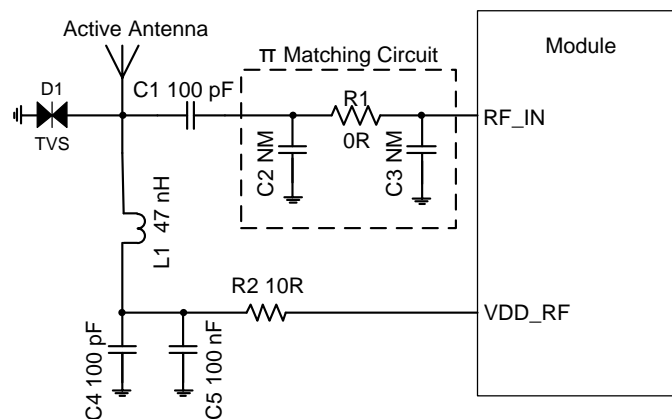

Figure 18: Active Antenna Reference Design without ANTON

The components C2, R1 and C3 are reserved for matching antenna impedance. By default, R1 is 0 Ω, while C2 and C3 are not mounted; C1 is 100 pF; D1 is an electrostatic discharge (ESD) protection device to protect the RF signal input from the potential damage caused by ESD.

An active antenna can use the power supply from the VDD_RF pin. In that case, the inductor L1 is used to prevent the RF signal from leaking into the VDD_RF and to prevent noise propagation from the VDD_RF to the antenna. The L1 inductor routes the bias voltage to the active antenna without losses. The recommended value of L1 is no less than 47 nH. The resistor R2 is used to protect the modules in case the active antenna is short-circuited to the ground plane.

The existing footprints in the matching circuit can be used to mount other type of components than the ones presented in the figure above. In that case, you must pay attention to the DC power supply. For example, if an inductor is mounted on the C1 footprint, then the circuit needs a DC-blocking capacitor between L1 and C1 to prevent short-circuiting of the DC power supply through the inductor to the ground. The same applies to the C2 footprint.

5.1.3.2. Active Antenna Reference Design with ANTON

All the modules can also reduce power consumption by controlling the power supply of active antenna through the ANTON pin.

The reference circuit for active antenna with ANTON function is given as below.

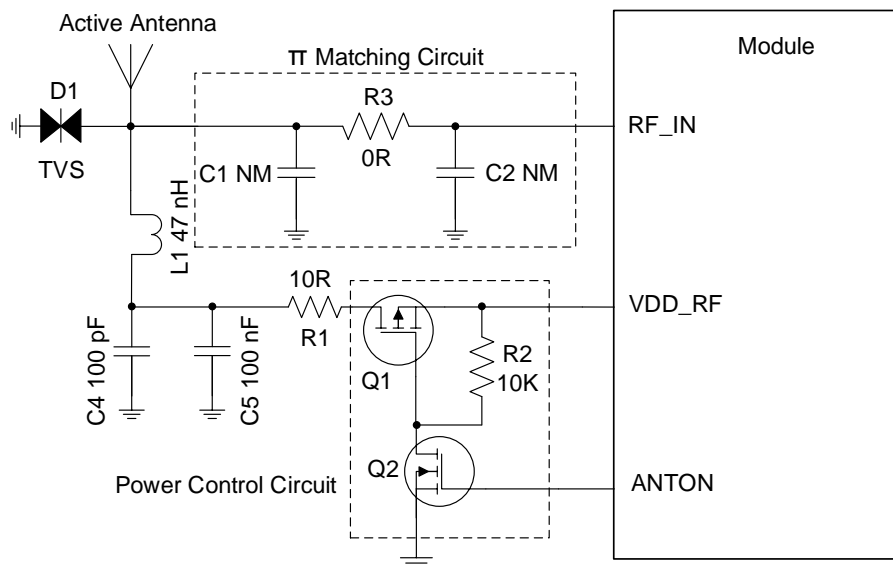

Figure 19: Reference Design for Active Antenna with ANTON

ANTON is an optional pin which can be used to control the power supply of the active antenna. When the ANTON pin is pulled down, MOSFET Q1 and Q2 are in high impedance state and the power supply for antenna is cut off. When ANTON pin is pulled high, it will make Q1 and Q2 in the on-state, and VDD_RF

will provide power supply for the active antenna. The high and low level of ANTON pin is determined by the modules' state.

For minimizing the current consumption, the value of resistor R2 should not be too small, and the recommended value is 10 k Ω .

5.1.4. Passive Antenna Reference Design

5.1.4.1. Passive Antenna Reference Design without Additional LNA

The following figure is a typical reference design of a passive antenna.

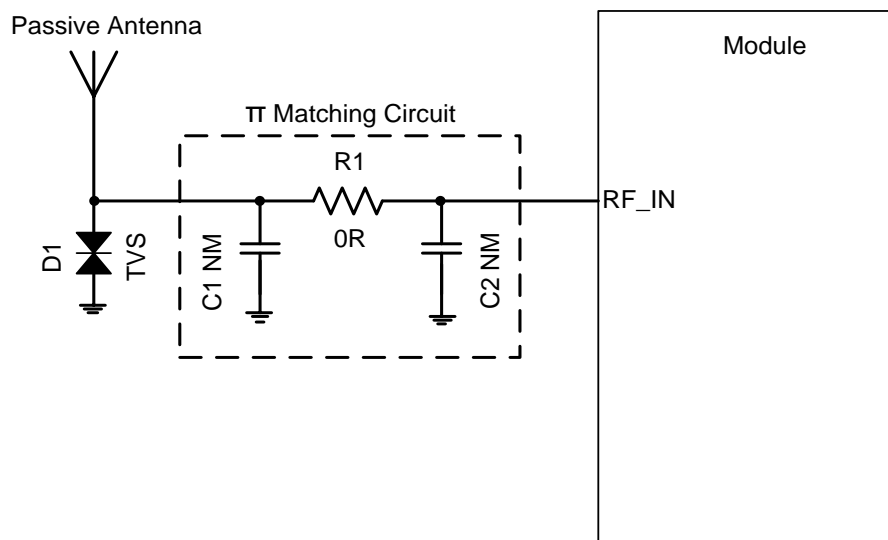

Figure 20: Passive Antenna Reference Design without Additional LNA

The components C1, R1 and C2 are reserved for matching antenna impedance. By default, R1 is 0 Ω , while C1 and C2 are not mounted. D1 is an electrostatic discharge (ESD) protection device to protect one signal line from the damage caused by ESD. The impedance of RF trace should be controlled to 50 Ω and the trace length should be kept as short as possible.

5.1.4.2. Passive Antenna Reference Design with Additional LNA

In order to improve the receiver sensitivity and reduce the TTFF, an additional LNA between the passive antenna and the module is recommended. The reference design is shown as below.

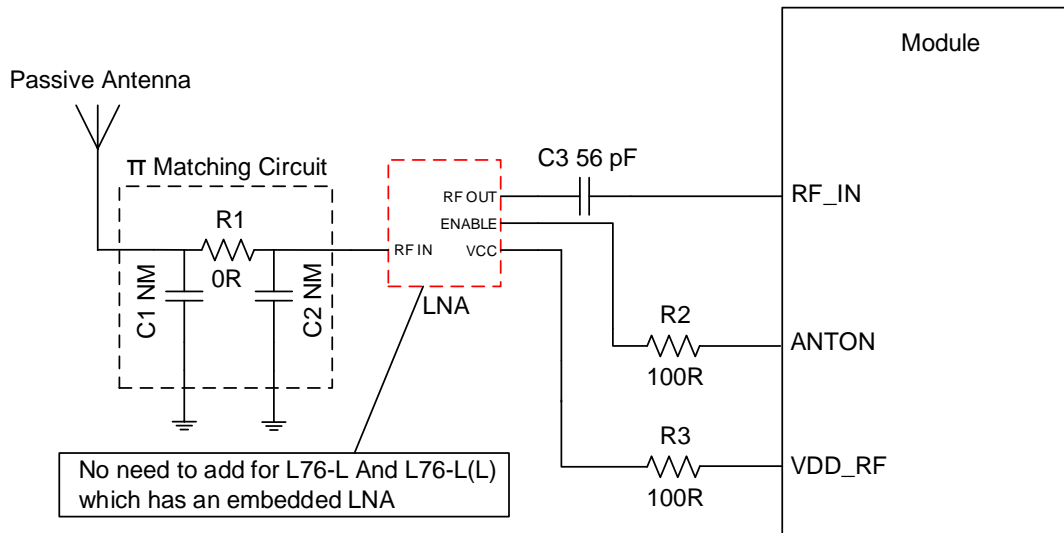

Figure 21: Reference Design for Passive Antenna with Additional LNA

C1, R1, C2 form a reserved matching circuit for passive antenna and LNA. By default, C1 and C2 are not mounted; R1 is 0 Ω. C3 is reserved for impedance matching between LNA and the module and the default value of C3 capacitor is 56 pF which you might optimize according to the real conditions. ANTON is an optional pin which can be used to control the ENABLE pin of an additional LNA.

NOTE

1. There is no need to use an additional LNA for L76-L and L76-L(L) modules, because there is already an embedded LNA inside these two modules.
2. The selected LNA should support both GPS and GLONASS system. For more information, please contact Quectel technical supports.
3. The power consumption of the device can be reduced by controlling the LNA ENABLE pin through the ANTON pin of the modules. If ANTON function is not used, please connect the LNA ENABLE pin to VCC and keep LNA always on.

5.2. Coexistence with Cellular Systems

Since GNSS signals are usually very weak, a GNSS receiver could be vulnerable to environmental interference. According to 3GPP specifications, a cellular terminal should transmit a signal of up to 33 dBm at GSM bands, or of about 24 dBm at WCDMA and LTE bands, or of about at 26 dBm at 5G bands. Therefore, coexistence with cellular systems must be optimized to avoid significant deterioration of the GNSS performance.

In a complex communication environment, interference signals can come from in-band and out-of-band signals. Therefore, interference can be divided into two types: in-band interference and out-of-band

interference, which are both described in this chapter.

In this chapter, you can also find suggestions for decreasing the impact of interference signals that will ensure the interference immunity of a GNSS receiver.

5.2.1. In-band Interference

In-band interference refers to the signal whose frequency is within or near the operating frequency range of a GNSS signal. For example, GPS L1 is centered at 1575.42 MHz with a bandwidth of 2.046 MHz. As shown in the figure below, the frequency of the interfering signal is within the GPS operation band, and the power of the interfering signal is higher than the power of the received GPS signal.

See the following figure for more details.

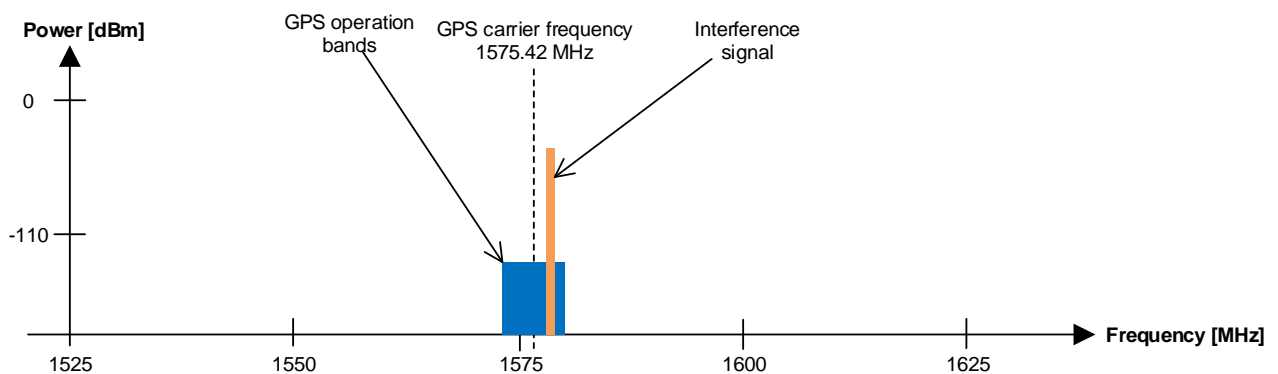

Figure 22: In-band Interference on GPS L1

The most common in-band interferences usually come from:

- Harmonics, caused by crystals, high-speed signal lines, MCUs, switch-mode power supply etc., or
- Intermodulation from different communication systems.

Common frequency combinations are presented in the table below. The table lists some probable in-band interferences generated by two kinds of out-of-band signal intermodulation, or the second harmonic of LTE Band 13.

Table 7: Intermodulation Distortion (IMD) Products

Source F1	Source F2	IM Calculation	IMD Products
GSM850/Band 5	Wi-Fi 2.4 GHz	F2 (2412 MHz) - F1 (837 MHz)	IMD2 = 1575 MHz
Band 1	n78	F2 (3500 MHz) - F1 (1925 MHz)	IMD2 = 1575 MHz
DCS1800/Band 3	PCS1900/Band 2	2 × F1 (1712.6 MHz) - F2 (1850.2 MHz)	IMD3 = 1575 MHz
PCS1900/Band 2	Wi-Fi 5 GHz	F2 (5280 MHz) - 2 × F1 (1852 MHz)	IMD3 = 1576 MHz
LTE Band 13	-	2 × F1 (786.9 MHz)	IMD2 = 1573.8 MHz

5.2.2. Out-of-band Interference

Strong signals transmitted by other communication systems can cause GNSS receiver saturation, thus greatly deteriorating its performance, as illustrated in the following figure. In practical applications, common strong interference signals originate from wireless communication modules, such as GSM, 3G, LTE, 5G, Wi-Fi and Bluetooth.

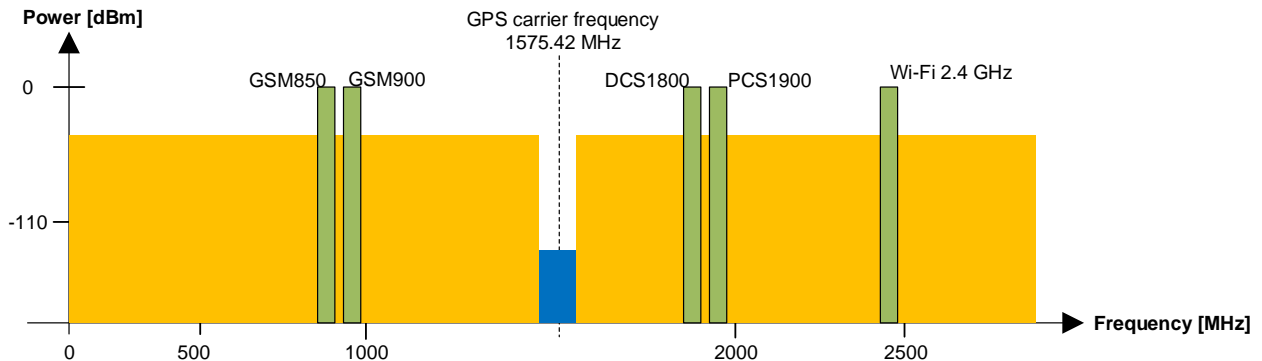

Figure 23: Out-of-band Interference on GPS L1

5.2.3. Ensuring Interference Immunity

There are several things you can do to decrease the impact of interference signals and thus ensure the interference immunity of a GNSS receiver:

- Keep the GNSS antenna away from interference sources;
- Add a band-pass filter in front of the GNSS module;
- Use shielding and multi-layer PCB and ensure adequate grounding;
- Optimize layout and component placement of the PCB and the whole device.

The following figure illustrates the interference source and its possible interference path. In a complex communication system, there are usually RF power amplifiers, MCUs, crystals, etc. These devices should be far away from a GNSS receiver, or a GNSS module. In particular, shielding should be used to prevent strong signal interference for power amplifiers. The cellular antenna should be placed away from a GNSS receiving antenna to ensure enough isolation. Usually, a good design should provide at least a 20 dB isolation between two antennas. Take DCS1800 for example, the maximum transmitted power of DCS1800 is around 30 dBm. After a 20 dB attenuation, the signal received by the GNSS antenna will be around 10 dBm, which is still too high for a GNSS module. With a GNSS band-pass filter with around 40 dB rejection in front of the GNSS module, the out-of-band signal will be attenuated to -30 dBm.

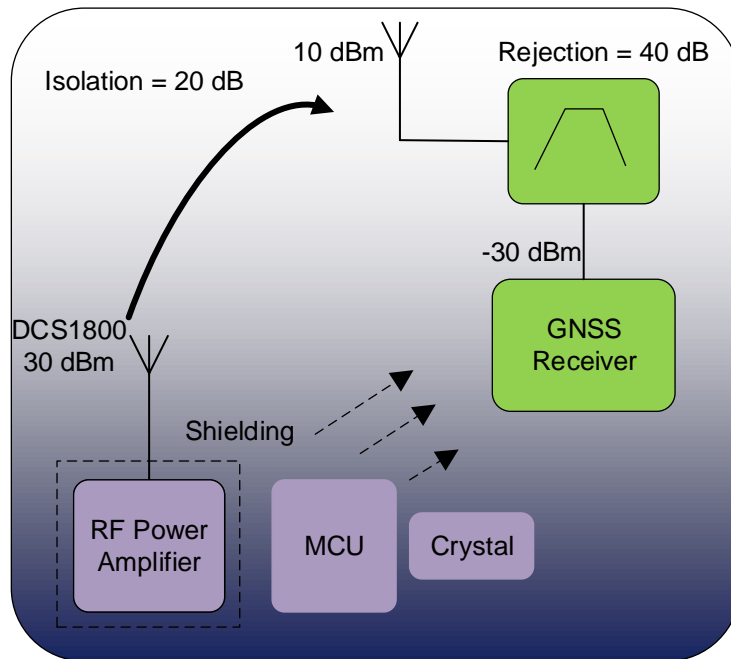

Figure 24: Interference Source and Its Path

5.3. Recommended Footprint

The figure below describes module footprint. These are recommendations, not specifications.

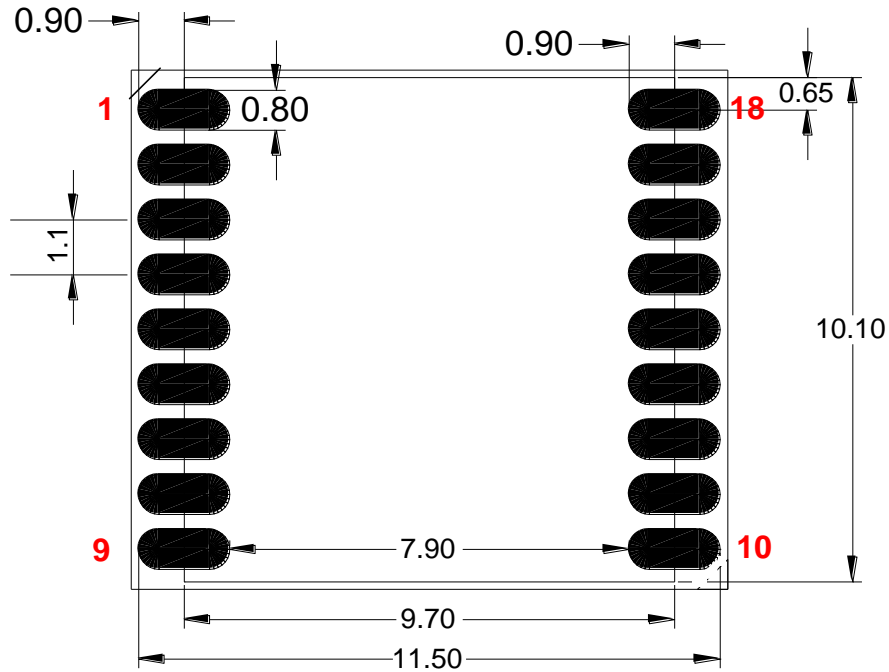

Figure 25: Recommended Footprint

NOTE

For easy maintenance, keep a distance of at least 3 mm between the module and other components on the PCB.

6 Electrical Specification

6.1. Absolute Maximum Ratings

Absolute maximum ratings for power supply and voltage on digital pins of the three modules are listed in table below.

Table 8: Absolute Maximum Ratings

Parameter	Description	Min.	Max.	Unit
VCC	Main Power Supply Voltage	-0.3	4.5	V
V_BCKP	Backup Supply Voltage	-0.3	4.5	V
V _{IN_IO}	Input Voltage at I/O Pins (L76&L76-L)	-0.3	3.1	V
	Input Voltage at I/O Pins (L76-L(L))	-0.3	2.1	V
P _{RF_IN}	Input Power at RF_IN	-	15	dBm
T storage	Storage Temperature	-40	90	°C

NOTE

Stressing the device beyond the “Absolute Maximum Ratings” may cause permanent damage. The product is not protected against over-voltage or reversed voltage. Therefore, it is necessary to use appropriate protection diodes to keep voltage spikes within the parameters given in the table above.

6.2. Recommended Operating Conditions

All specifications are at an ambient temperature of +25°C. Extreme operating temperatures can significantly impact the specified values. Applications operating near the temperature limits should be tested to ensure the validity of the specification.

Table 9: Recommended Operating Conditions

Parameter	Description	Min.	Typ.	Max.	Unit
VCC	Main Power Supply Voltage	2.8	3.3	4.3	V
V_BCKP	Backup Supply Voltage	1.5	3.3	4.5	V
I/O_Domain	Domain Voltage at Digital I/O Pins (L76&L76-L)	-	2.8	-	V
	Domain Voltage at Digital I/O Pins (L76-L(L))	-	1.8	-	V
V _{IL}	Digital I/O Pin Low-Level Input Voltage (L76&L76-L)	-0.3	-	0.7	V
	Digital I/O Pin Low-Level Input Voltage (L76-L(L))	-0.3	-	0.45	V
V _{IH}	Digital I/O Pin High-Level Input Voltage (L76&L76-L)	2.1	-	3.1	V
	Digital I/O Pin High-Level Input Voltage (L76-L(L))	1.35	-	2.1	V
V _{OL}	Digital I/O Pin Low-Level Output Voltage (L76&L76-L)	-	-	0.42	V
	Digital I/O Pin Low-Level Output Voltage (L76-L(L))	-	-	0.27	V
V _{OH}	Digital I/O Pin High-Level Output Voltage (L76&L76-L)	2.4	2.8	-	V
	Digital I/O Pin High-Level Output Voltage (L76-L(L))	1.53	1.8	-	V
RESET_N (L76&L76-L)	Low-Level Input Voltage	-0.3	-	0.7	V
RESET_N (L76-L(L))	Low-Level Input Voltage	-0.3	-	0.45	V
VDD_RF	VDD_RF Voltage	-	VCC	-	V

Parameter	Description	Min.	Typ.	Max.	Unit
T_operating	Operating Temperature	-40	25	+85	°C

NOTE

Operation beyond the "Operating Conditions" is not recommended and extended exposure beyond the "Operating Conditions" may affect device reliability.

6.3. ESD Protection

Static electricity occurs naturally and it may damage the module. Therefore, applying proper ESD countermeasures and handling methods is imperative. For example, wear anti-static gloves during the development, production, assembly, and testing of the module; add ESD protective components to the ESD sensitive interfaces and points in the product design.

Measures to ensure protection against ESD damage while handling the module:

- When mounting the module onto a motherboard, make sure to connect the GND first, and then the RF_IN pin.
- When handling the RF_IN pin, do not come into contact with any charged capacitors or materials that may easily generate or store charges (such as patch antenna, coaxial cable, and soldering iron).
- When soldering the RF_IN pin, make sure to use an ESD safe soldering iron (tip).

7 Mechanical Dimensions

This chapter describes the mechanical dimensions of the three modules. All dimensions are in millimeters (mm). The dimensional tolerances are ± 0.20 mm, unless otherwise specified.

7.1. Top, Side and Bottom View Dimensions

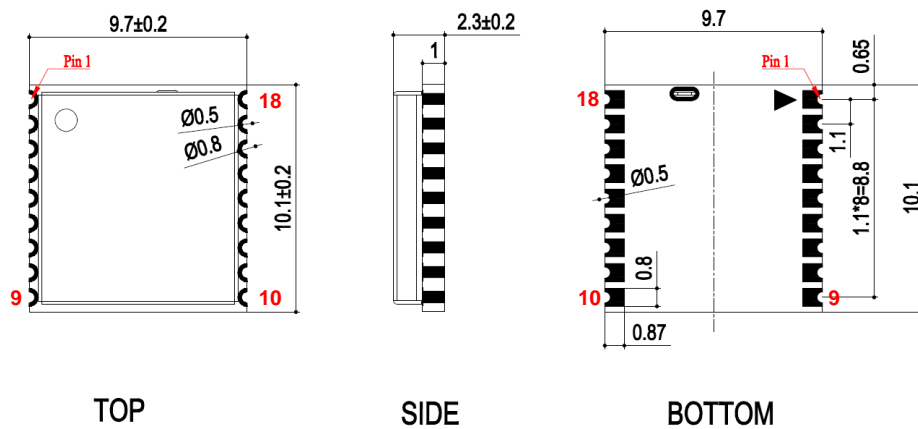

Unlabeled tolerance: ± 0.2 mm

Figure 26: Top, Side and Bottom View Dimensions

NOTE

The package warpage level of the modules conforms to the *JEITA ED-7306* standard.

7.2. Top and Bottom Views

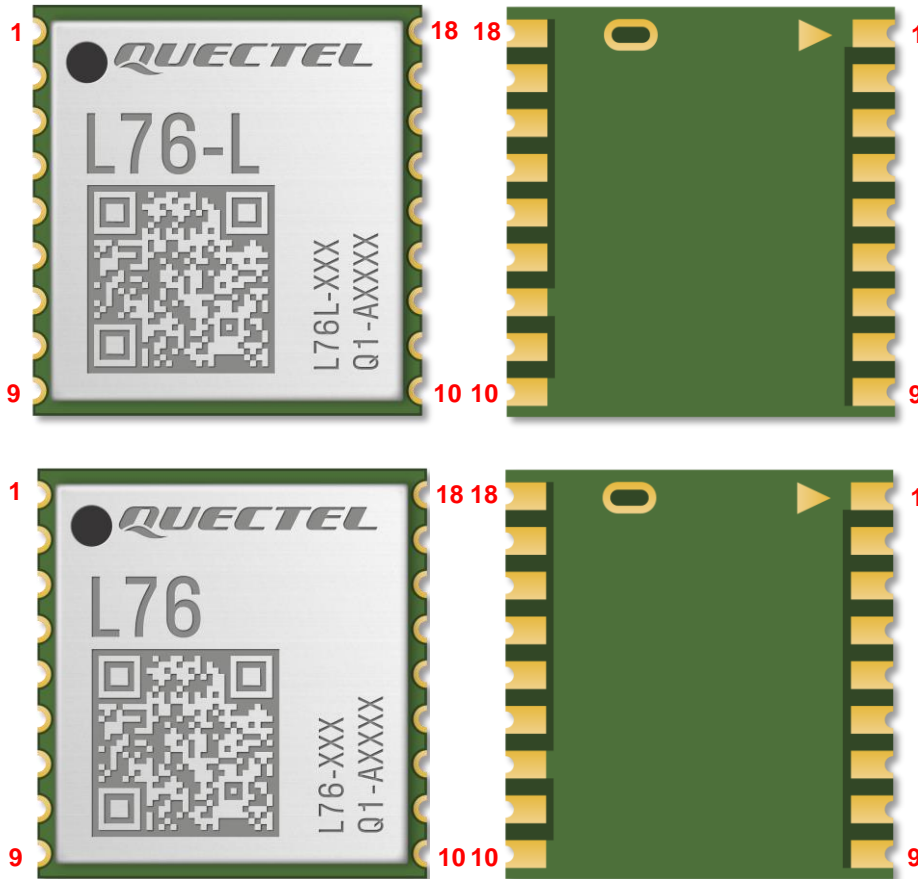

Figure 27: Top and Bottom Views

NOTE

The above images are for illustrative purposes only and may differ from the actual modules. For authentic appearance and label, see the module received from Quectel.

8 Product Handling

8.1. Packaging

All the three modules are delivered as a reeled tape, which enables efficient production, set-up and dismantling of production batches. It is shipped in a vacuum-sealed packaging to prevent moisture intake and electrostatic discharge.

8.1.1. Tapes

The following figure shows the position of the three modules when delivered in tape and the dimensions of the tape.

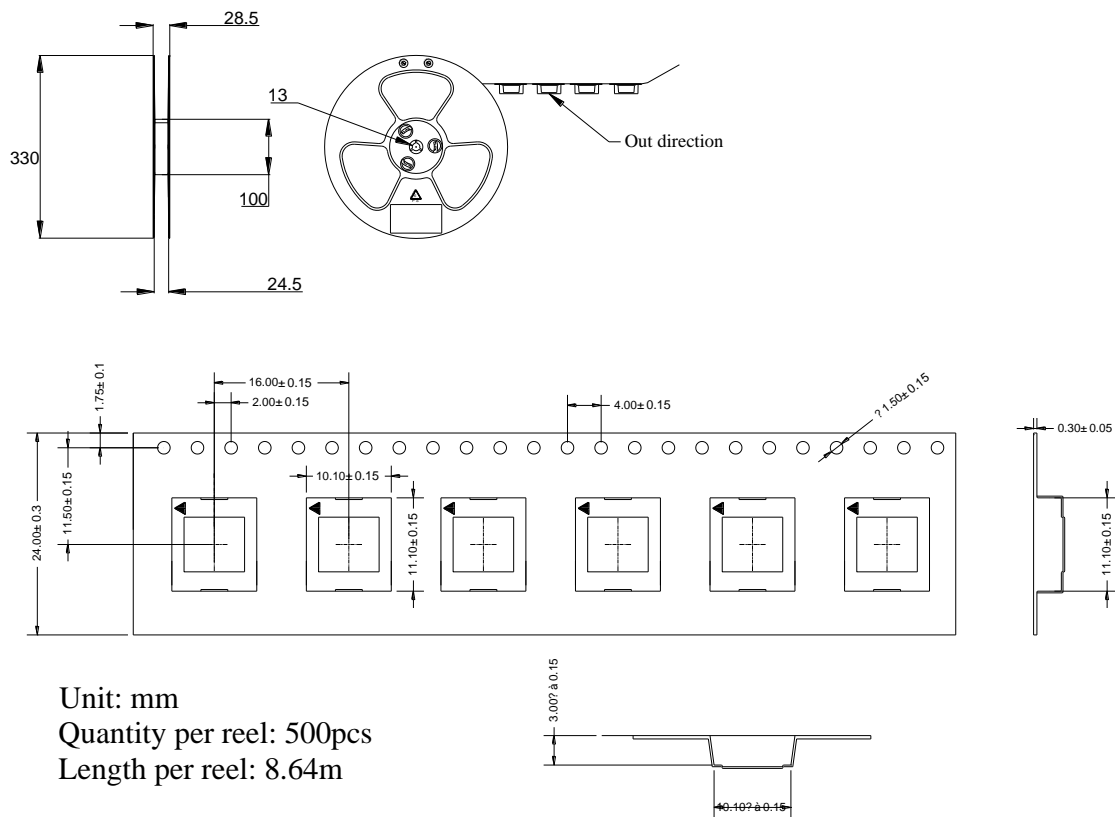

Figure 28: Tape and Reel Specifications

8.1.2. Reels

Each reel contains 500 Quectel GNSS modules. See the figure above.

Table 10: Reel Packaging

Model Name	MOQ	Minimum Package (MP): 500 pcs	Minimum Package x 4 = 2000 pcs
L76/L76-L /L76-L(L)	500 pcs	Size: 370 mm x 350 mm x 56 mm N.W: 0.25 kg G.W: 1.0 kg	Size: 380 mm x 250 mm x 365 mm N.W: 1.1 kg G.W: 4.4 kg

8.2. Storage

The module is provided in a vacuum-sealed packaging. MSL of the module is rated at 3. The storage requirements are shown below.

1. Recommended Storage Condition: the temperature should be 23 ±5 °C and the relative humidity should be 35–60 %.
2. Shelf life (in a vacuum-sealed packaging): 12 months in Recommended Storage Condition.
3. Floor life: 168 hours ⁵ in a factory where the temperature is 23 ±5 °C and relative humidity is below 60 %. After the vacuum-sealed packaging is removed, the module must be processed in reflow soldering or other high-temperature operations within 168 hours. Otherwise, the module should be stored in an environment where the relative humidity is less than 10 % (e.g., a dry cabinet).
4. The module should be pre-baked to avoid blistering, cracks and inner-layer separation in PCB under the following circumstances:
 - The module is not stored in Recommended Storage Condition;
 - Violation of the third requirement above;
 - Vacuum-sealed packaging is broken, or the packaging has been removed for over 24 hours;
 - Before module repairing.
5. If needed, the pre-baking should meet the requirements below:

⁵ This floor life is only applicable when the environment conforms to *IPC/JEDEC J-STD-033*. It is recommended to start the solder reflow process within 24 hours of removing the package if the temperature and moisture do not conform, or if it is not certain that they conform to *IPC/JEDEC J-STD-033*. Do not unpack the modules in large quantities until they are ready for soldering.

- The module should be baked for 8 hours at 120 ±5 °C;
- The module must be soldered to PCB within 24 hours after the baking, otherwise it should be put in a dry environment such as in a dry cabinet.

NOTE

1. To avoid blistering, layer separation and other soldering issues, extended exposure of the module to the air is forbidden.
2. Take the module out of the packaging and put it on high-temperature-resistant fixtures before baking. If shorter baking time is desired, see *IPC/JEDEC J-STD-033* for the baking procedure.
3. Pay attention to ESD protection, such as wearing anti-static gloves, when touching the module.

8.3. Manufacturing and Soldering

Push the squeegee to apply solder paste on the stencil surface, thus making the paste fill the stencil openings and then penetrate the PCB. Apply proper force on the squeegee to produce a clean stencil surface on a single pass. For more information about the stencil thickness of the module, see [document \[5\] module SMT application note](#).

The recommended peak reflow temperature should be 235–246 °C, with 246 °C as the absolute maximum reflow temperature. To avoid module damage caused by repeated heating, it is recommended to mount the module only after reflow soldering the other side of the PCB. The recommended reflow soldering thermal profile (lead-free reflow soldering) and related parameters are shown in the figure and table below.

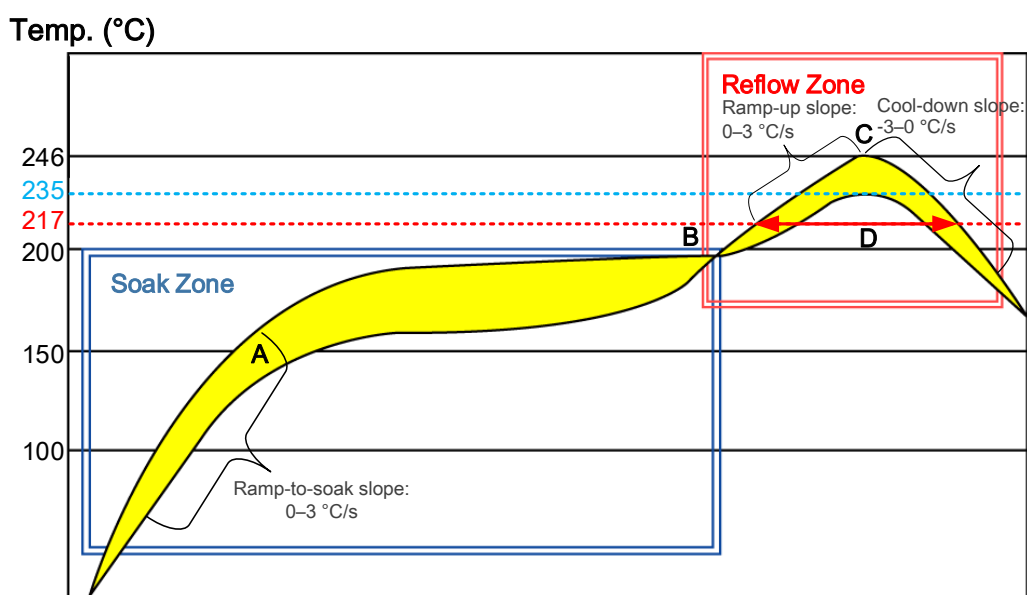

Figure 29: Recommended Reflow Soldering Thermal Profile

Table 11: Recommended Thermal Profile Parameters

Factor	Recommendation
Soak Zone	
Ramp-to-soak Slope	0–3 °C/s
Soak Time (between A and B: 150 °C and 200 °C)	70–120 s
Reflow Zone	
Ramp-up Slope	0–3 °C/s
Reflow Time (D: over 217 °C)	40–70 s
Max. Temperature	235–246 °C
Cooling Down Slope	-3–0 °C/s
Reflow Cycle	
Max. Reflow Cycle	1

NOTE

1. The above profile parameter requirements are for the measured temperature of the solder joints. Both the hottest and coldest spots of solder joints on the PCB should meet the above requirements.
2. During manufacturing and soldering, or any other processes that may require direct contact with the module, **NEVER** wipe the module shielding can with organic solvents, such as acetone, ethyl alcohol, isopropyl alcohol, and trichloroethylene. Otherwise, the shielding can may become rusty.
3. The module shielding can is made of cupronickel base material. The Neutral Salt Spray Test has shown that after 12 hours the laser-engraved label information on the shielding can is still clearly identifiable and the QR code is still readable, although white rust may be found.
4. If a conformal coating is necessary for the module, **DO NOT** use any coating material that may react with the PCB or shielding cover. Prevent the coating material from penetrating the module shield.
5. Avoid using ultrasonic technology for module cleaning since it can damage crystals inside the module.
6. Due to SMT process complexity, contact Quectel Technical Support in advance regarding any ambiguous situation, or any process (e.g., selective soldering, ultrasonic soldering) that is not addressed in [document \[5\] module SMT application note](#).

9 Labelling Information

The label of the Quectel GNSS modules contains important product information. The location of the product type number is shown in figure below.

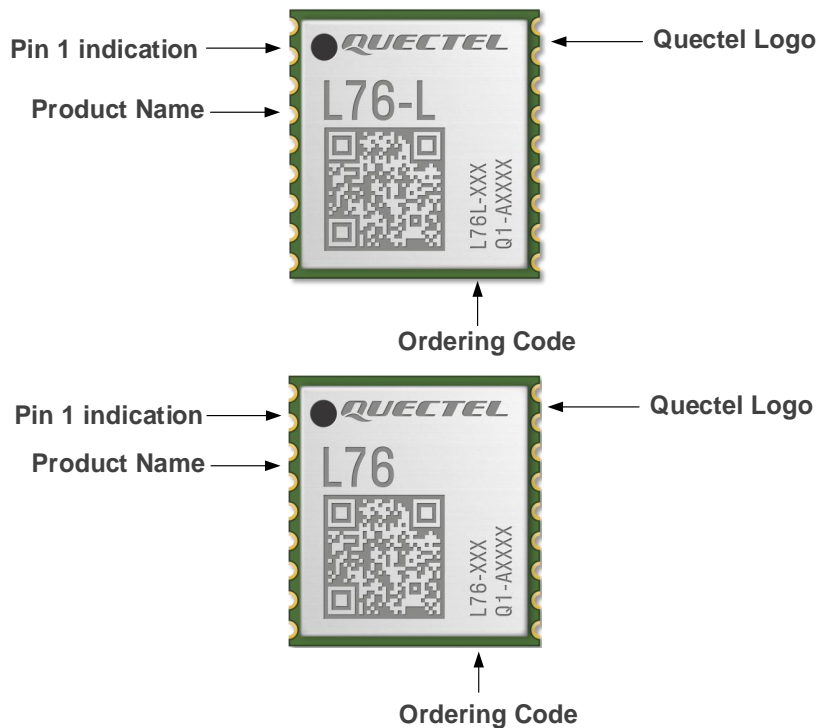

Figure 30: Labelling Information

The image above is for illustrative purposes only and may differ from the actual modules. For authentic appearance and label, see the module received from Quectel.

10 Appendix References

Table 12: Related Documents

SN	Document Name
[1]	Quectel Lx0&Lx6&LC86L&LG77L GNSS Protocol Specification
[2]	Quectel Lx6&Lx0&LC86L&LG77L AGNSS Application Note
[3]	Quectel Lx6&LG77L I2C Application Note
[4]	Quectel_GNSS_Antenna_Selection&Application_Guide
[5]	Quectel Module SMT Application Note

Table 13: Terms and Abbreviations

Abbreviation	Description
AGNSS	Assisted Global Positioning System
AIC	Active Interference Cancellation
CEP	Circular Error Probable
CNR or C/N	Carrier-to-noise Ratio
DCE	Data Communications Equipment
DCS1800	Digital Cellular System at 1800 MHz
DR	Dead Reckoning
DTE	Data Terminal Equipment
EASY	Embedded Assist System
EGNOS	European Geostationary Navigation Overlay Service
EPO	Extended Prediction Orbit

Abbreviation	Description
ESD	Electrostatic Discharge
GAGAN	GPS Aided Geo Augmented Navigation
Galileo	Galileo Satellite Navigation System (EU)
GLONASS	Global Navigation Satellite System (Russian)
GNSS	Global Navigation Satellite System
GPS	Global Positioning System
GSM	Global System for Mobile Communications
G.W	Gross Weight
I/O	Input/Output
I2C	Inter-integrated Circuit
IC	Integrated Circuit
NavIC	Indian Regional Navigation Satellite System
kbps	kilobits per second
LCC	Leadless Chip Carrier (package)
LDO	Low-dropout Regulator
LNA	Low-noise Amplifier
LTE	Long Term Evolution
LTO	Long-term Orbit
Mbps	Megabits per second
MCU	Microcontroller Unit/Microprogrammed Control Unit
MEMS	Micro-electro-mechanical System
MOQ	Minimum Order Quantity
MP	Mass Production
MSAS	Multi-functional Satellite Augmentation System (Japan)
MSL	Moisture Sensitivity Levels

Abbreviation	Description
N. W	Net Weight
NMEA	National Marine Electronics Association
OC	Open Connector
PCB	Printed Circuit Board
PMU	Power Management Unit
ppm	parts per million
1PPS	One Pulse Per Second
PQ	Quectel Proprietary Protocol
PSRR	Power Supply Rejection Ratio
QR (code)	Quick Response (Code)
QZSS	Quasi-Zenith Satellite System
RAM	Random Access Memory
RF	Radio Frequency
RHCP	Right Hand Circular Polarization
RMC	Recommended Minimum Specific GNSS Data
RoHS	Restriction of Hazardous Substances
ROM	Read Only Memory
RTC	Real-time Clock
RTK	Real-time Kinematic
RTS	Ready to Send/Request to Send
RXD	Receive Data
3GPP	3rd Generation Partnership Project
SAW	Surface Acoustic Wave
SBAS	Satellite-Based Augmentation System
SMD	Surface Mount Device

Abbreviation	Description
SMT	Surface Mount Technology
SN	Serial Number
SNR	Signal-to-noise Ratio
SPI	Serial Peripheral Interface
SRAM	Static Random Access Memory
TCXO	Temperature Compensated Crystal Oscillator
TTFF	Time to First Fix
TVS	Transient Voltage Suppressor
UART	Universal Asynchronous Receiver/Transmitter
UTC	Coordinated Universal Time
VSWR	Voltage Standing Wave Ratio
WAAS	Wide Area Augmentation System
XTAL	External Crystal Oscillator